

# Manual E796

2000 M2CP



When communicating with EIM for replacement parts or for technical questions, we **MUST** have actuator nameplate information, including Job, Serial, and Model numbers. This allows us to check EIM records of your actuator.

When ordering parts, specify repair part by EIM part number and description from drawings furnished with actuator.

EIM Parts Department Fax (281) 261-3834

TABLE OF CONTENTS	Page
Storage Instructions .....	2
M2CP Electrical Hook Up .....	2
Assembly to Valves .....	3
Limit Switch Setting Instructions .....	4
Torque Switch Setting Instructions .....	5
MDPI & Potentiometer Gear Box .....	5
Futronic II 83957 Calibration .....	6
Trouble Shooting & Wiring Diagram Symbols .....	7

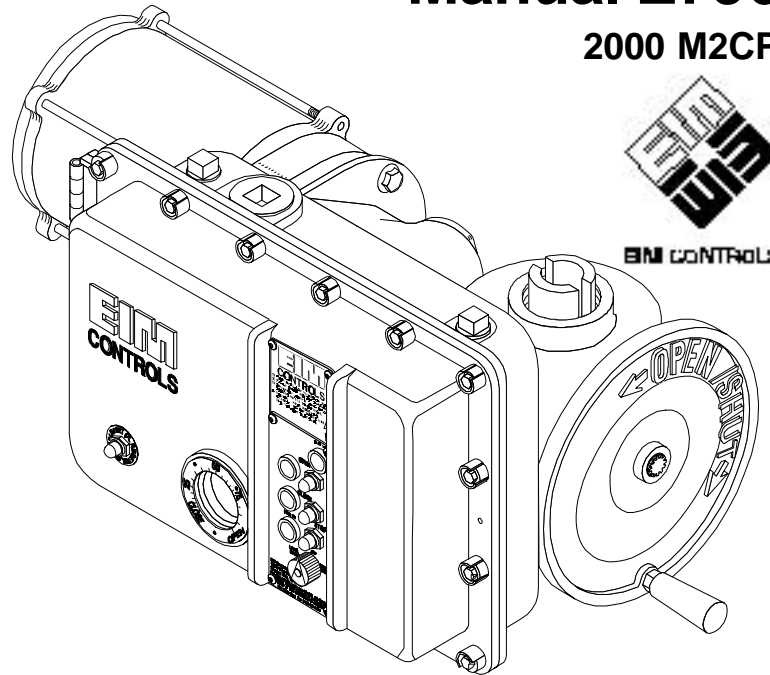

## DO

1. **DO follow proper storage procedures.** Improper storage will void warranty.
2. **DANGER: DO check for proper motor rotation.** If valve goes wrong direction when button is pushed, you have no torque or limit protection. 3-Phase incoming power voltage must have 2 wires reversed.
3. **DO read and follow procedures** before attempting to energize actuator.
4. **DO cut off electric power before opening switch compartment.**
5. **DO install relief vent in highest point of gearbox.**
6. **DO use valve stem covers** of sufficient length.
7. **DO clean electrical enclosure flange** thoroughly & lightly grease before closing.
8. **DO secure electrical enclosure bolts** (10-12 ft-lbs).
9. **DO follow an annual maintenance procedure.**
10. **DO use caution** when working on, with, or around valves and actuators. You can be dealing with high pressures, forces, voltages and flammable media.

## DON'T

1. **Don't Start-up** without reading this manual.
2. **Don't stack actuators.**
3. **Don't store actuator on the ground unprotected.**
4. **Don't lift the unit** by clutch lever or handwheel.
5. **Don't lift a valve assembly** by electrical actuator.
6. **Don't operate electrically without first** checking proper phase rotation, torque and position limit switch adjustments (follow instructions on pgs 2, 4 and 5).
7. **Don't plug actuator motor** by starting and stopping repeatedly to move a too stiff valve. Check for cause.
8. **Don't jumper torque switches** except as recommended by Wiring Diagram or Valve Manufacturer.
9. **Don't use oversize thermal motor overloads** to eliminate tripping problem. Find cause and correct.
10. **Don't use a cheater** to force the handwheel. You can damage gearing and shafts. Find cause and correct.
11. **Don't torque seat valve,** sluice gate or damper unless the valve manufacturer recommends.

## LUBRICATION

EIM Actuators are factory filled with a high quality lubricant carefully selected to insure actuator performance under specified operating conditions. Refer to EIM JOB SPEC SHEET to identify the lubricant provided. Normal operation *may not* require lubricant replacement.

## MAINTENANCE

**At least once a year a check should be made of your EIM actuator.**

- a) Disconnect **all** electrical power to actuator.
- b) Open electrical enclosure. Inspect & tighten all electrical connections.
- c) Visually inspect for any electrical or mechanical damage. Replace worn or damaged components.
- d) Check lubrication consistency and level. Fill or replace if required.

## PRESSURE RELIEF

During operation of electric actuator, the gear temperature increase in combination with variations of outdoor temperature will cause a small pressure build-up within actuator gear box. EIM furnishes Pressure Relief Vent Fitting Part No. 83385. Placement on Actuator can be determined only after field location and position of valve has been determined. Select the highest 1/2 NPT vent location on actuator gear box; remove 1/2 NPT plug and replace with 83385. The possible locations of vent are shown on EIM Outline Drawing.

## SHORT TERM STORAGE

(Stored at Job Site less than one year from shipment)

1. Actuator should be stored with motor shaft in horizontal position and electrical enclosure in either the horizontal or vertical position.
2. Actuator should be stored indoors free from job site dirt, mud, moisture and temperature changes.
3. If indoor storage is not possible, the actuator must be stored off the ground above possible water or snow level. Remove M2CP and store with other electrical and electronic equipment in protected warehouse. If M2CP is not removed, Space heater MUST be energized to protect electrical controls.
4. EIM supplies NPT plugs in each conduit entry. Do not remove until electrical hook-up. The customer conduit should be routed to enter electrical enclosure at 1-1/2 (1.50) NPT located at lowest point, so condensation does not drain into enclosure and damage parts.
5. Cover units loosely with a plastic sheet. This serves as partial protection from rain.

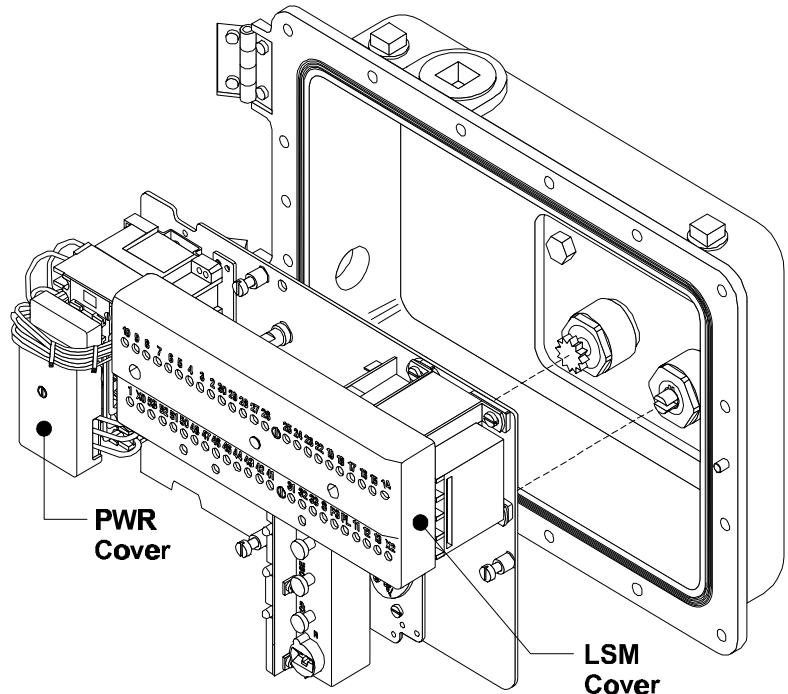

PWR Cover

LSM Cover

**FAILURE TO STORE ACTUATOR PROPERLY WILL VOID WARRANTY OF ELECTRICAL & ELECTRONIC COMPONENTS**

## LONG TERM STORAGE

(Stored more than one year from shipment)

1. Store indoors or M2CP should be removed and stored in a protected area. Follow procedures of short term storage.

## M2CP ELECTRICAL HOOK-UP

Remove PWR and TBM covers to expose terminals for customer wiring.

**EIM Modular Control Package (M2CP)** is available configured in many combinations of electrical and electronic parts. Refer to **WIRING DIAGRAM** and **EIM JOB SPEC SHEET** for components provided by EIM. Connect control wires to TBM and Power (motor) Voltage to PWR terminals. If optional M2CP mounted circuit breaker was specified, connect power voltage leads to circuit breaker. EIM terminal blocks are furnished with wire binding screw connectors with rising captive plates, allowing field connection by several methods: 1) strip and connect bare wire, 2) strip and install wire ferrule, 3) strip and install crimp-on insulated or non-insulated ring tongue or similar terminal. Circuit Breaker accepts 1) bare wire strip, or 2) wire ferrule.

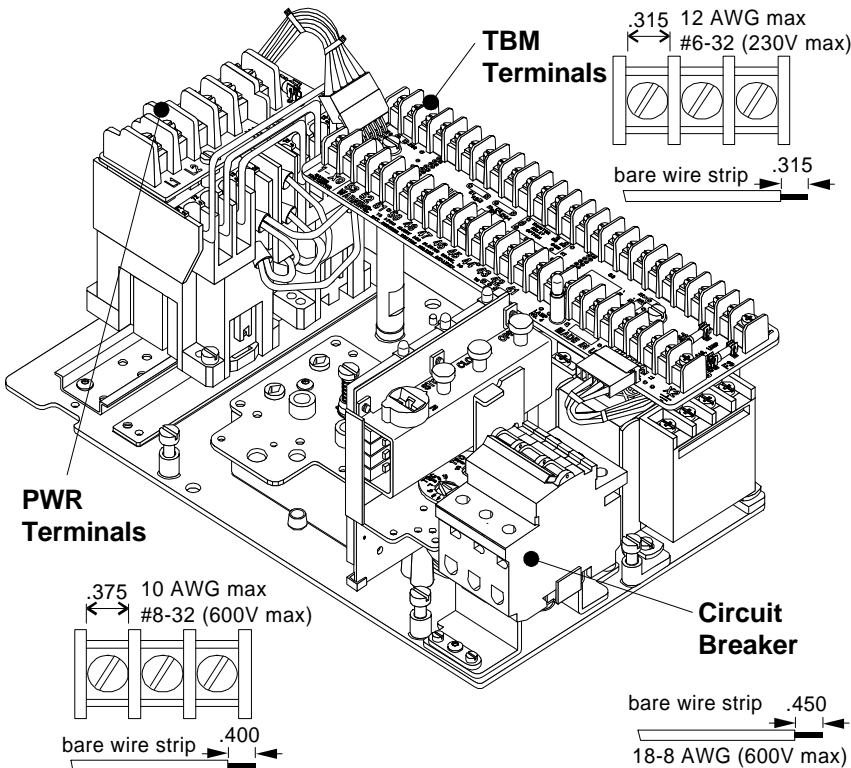

### Electrical Hook-up

**STEP 1.** Move valve to mid-position by handwheel. This will allow sufficient time to stop actuator in case of improper hook-up or reversed incoming power voltage phases.

**STEP 2.** Identify a means of removing power from actuator during check out. Be sure no erroneous remote control signal can be received causing actuator to energize.

**STEP 3.** Energize Open control to check operation of contactor and pushbuttons. Open controls must move valve in Open direction. If valve Closes, actuator must be stopped and any (2) two power voltage leads reversed to correct voltage phasing.

**CAUTION:** If voltage is improperly phased, Torque and Position Limit Switches are not in circuit to protect valve.

**STEP 4.** Seal all field conduit entries in accordance with National Electric Code.

## ASSEMBLY TO VALVES - Threaded Valve Stem

### LOCKNUT LOCKPIN INSTALLATION

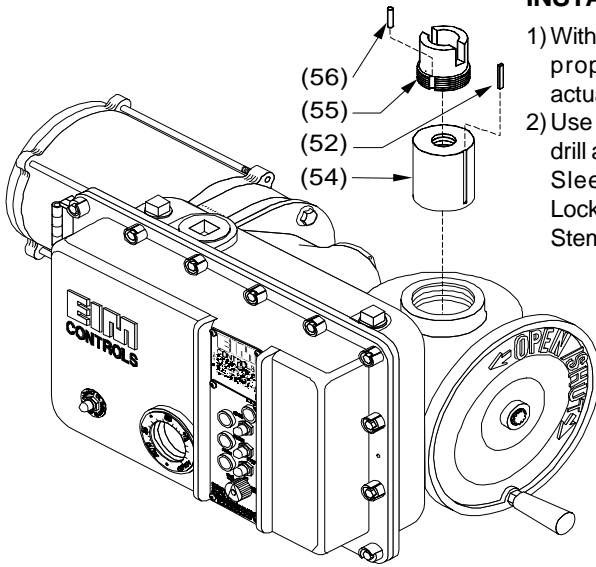

- 1) With actuator in place on valve, ensure proper flange mating and valve actuator orientation.
- 2) Use a number 30 (.1285) drill bit to drill a hole 3/4 inch deep into the Drive Sleeve assembly threads for the Locknut Lockpin (56) using groove in Stem Nut Locknut as drill guide.
- 3) Install Locknut Lockpin (56) into drilled hole to prevent Stem Nut Locknut from working loose and turning.

**Note:** When installing, the Locknut Lockpin - it should extend 1/4 inch above the Drive Sleeve assembly to allow for future removal.

### STEM NUT INSTALLATION (MULTI-TURN)

- 1) Unscrew Locknut (55) holding Bronze Stem Nut (54) and remove the Stem Nut and Key (52).
- 2) Lubricate Stem and run Stem Nut down Stem to check acme thread fit, then remove Stem Nut and set aside.
- 3) Lower actuator over Stem onto valve flange. The screws thru valve flange into actuator must engage a minimum of one full screw diameter deep into bottom base and be tightened to a preload. See assembly drawing for screw size and torque to tighten properly.

### MOUNTING SCREWS

If EIM supplied adaptation, the mounting screws are included. If adaptation to valve was the responsibility of others, the mounting screws are *not* furnished by EIM. Screws thru adapter MUST engage a minimum of one screw diameter deep into EIM actuator base.

- 4) Screw Stem Nut on Stem until it enters Drive Sleeve. Line (52) Key and (54) Drive Sleeve keyway and insert (52) Key.
- 5) Turn handwheel in Open direction, pulling Stem Nut into Drive Sleeve until it bottoms out (valve will begin to open).

### CAUTION: LOCKNUT MUST BE TIGHT AGAINST STEM NUT.

- 6) Lower Locknut (55) over Valve Stem and screw into place firmly against top of Stem Nut. Tap Locknut ears using brass drift until tight.

### THRUST SPOOL (Model 4000 & 5000)

- 1) Locate Thrust Mounting bolts.
- 2) Remove eight mounting bolts and separate Spool from actuator.
- 3) Position Spool over Valve Stem. Thread Spool onto Valve Stem until it meets valve plate.
- 4) Bolt and secure Spool onto valve.
- 5) Position actuator above Spool. Lower actuator onto Spool while manually rotating the unit until ears on Stem Nut and ears on main Drive Sleeve mesh.
- 6) Grease flange face before securing unit to Spool.
- 7) Re-install thrust plate mounting bolts. Tighten to proper torque.

**NOTE:** Reverse procedure if Stem Nut needs to be replaced. Actuator does not need to be returned to factory for this procedure.

### (Quarter-Turn) SPLINE BUSHING

EIM removable Spline Bushing allows easy adaptation to valve shaft diameter and Key. Actuator may be rotated with respect to valve shaft for unexpected or awkward field installations.

- 1) Move valve to full Open or Close.
- 2) Place Spline Bushing on valve shaft with Key and tighten set screw.
- 3) Using handwheel on actuator, move gear position indicator arrow to full Open or Close (the position in Step 1)
- 4) Position actuator so Spline Bore is correctly aligned with the Spline Bushing on stem shaft.
- 5) Move actuator onto shaft until flange faces properly mate. Secure with screws thru the adapter flange into base of actuator.

## Quarter-Turn Valve STOP SETTING PROCEDURE

Built-in mechanical stops are provided to prevent handwheel operation beyond total valve travel ( $90 \pm 6^\circ$ ). End of travel stops are independently adjusted, locked in place and sealed.

### Type P, Q & R (top mount)

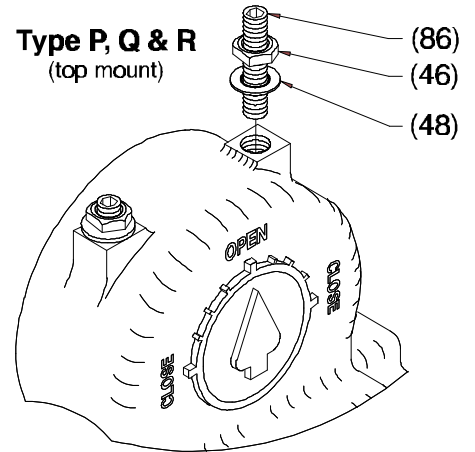

Loosen both Locknuts (46) and back out two Stopbolts (86) to allow valve to close and open fully. Insure Electrical Travel Limit Switches have been adjusted (see pg. 4).

- 1) Run actuator electrically to full Close.
- 2) Screw Close (86) Stopbolt in until it seats, then back off 1/2 turn. Install (48) Washer and tighten (46) Locknut.
- 3) Run actuator electrically to full Open.
- 4) Screw Open (86) Stopbolt in until it seats, then back off 1/2 turn. Install (48) Washer and tighten (46) Locknut.

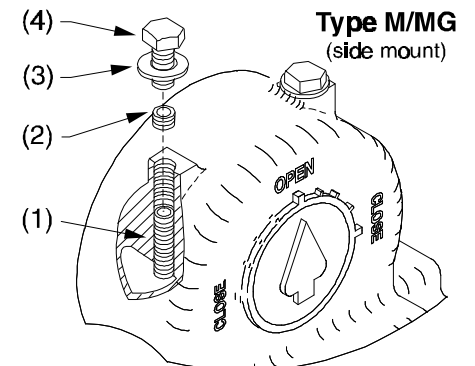

Back out two Stopbolts (1) to allow valve to close and open fully. Set Travel Limit Switches (see pg. 4).

- 1) Run actuator electrically to full Close.
- 2) Screw Close (1) Stopbolt in until it seats, then back off 1/2 turn. Tighten (2) Lockscrew.
- 3) Run actuator electrically to full Open.
- 4) Screw Open (1) Stopbolt in until it seats; back off 1/2 turn. Tighten Locknut.
- 5) Install (3) & (4) Seal Washer & Screw.

**CAUTION:** Do not set actuator position Limit Switches to drive into mechanical stops. Damage can occur if unit is repeatedly stalled into end stops.

## LIMIT SWITCH SETTING INSTRUCTIONS

### BEFORE MAKING LIMIT SWITCH SETTING:

1. Move valve to mid-position (use handwheel).
2. Phase the power (motor) voltage and make sure that open contactor moves valve Open and close contactor moves valve Closed.

**DANGER: Improper power voltage phasing eliminates protection of both position limit switch and torque switches, risking valve damage.**

### TO SET OPEN LIMIT SWITCH (LSO)

1. **Open valve** during handwheel operation note rotation direction of screwdriver (fig. 1) in LSO Adjusting Shaft. After valve is fully Open, Close it three handwheel turns to allow for coasting when motor is actuated.
2. **Disengage spring loaded gear:** Push Disengage Shaft in (fig. 2a) down, then rotate 90° so shaft is captured down. This will disengage limit switch gears from spring loaded drive gear.

**TIP: many turns may be required to set limit switches; it may be convenient to use a reversible variable speed drill to rotate the adjusting shafts instead of a screwdriver.**

3. **Line up LSO indicator:** If switch rotor arrow does not line with round holes (within  $\pm 15^\circ$ ) on plate as shown in fig. 3a, rotate screwdriver in same direction noted in Step 1 until switch just rotates. If arrows line up as shown in fig. 3b, rotate screwdriver in the opposite direction until switch just rotates.
4. **Re-engage** the spring-loaded drive gear by rotating disengage shaft in fig. 2a. Spring loaded disengage shaft will rise.
5. **IMPORTANT: to insure limit switch gears have re-engaged properly with spring loaded drive gear, firmly "jiggle" (rotate) all adjusting shafts with screwdriver back and forth. Proper engagement has been made if all shafts (LSC, LSO, LSA & LSB) will not turn with screwdriver.**

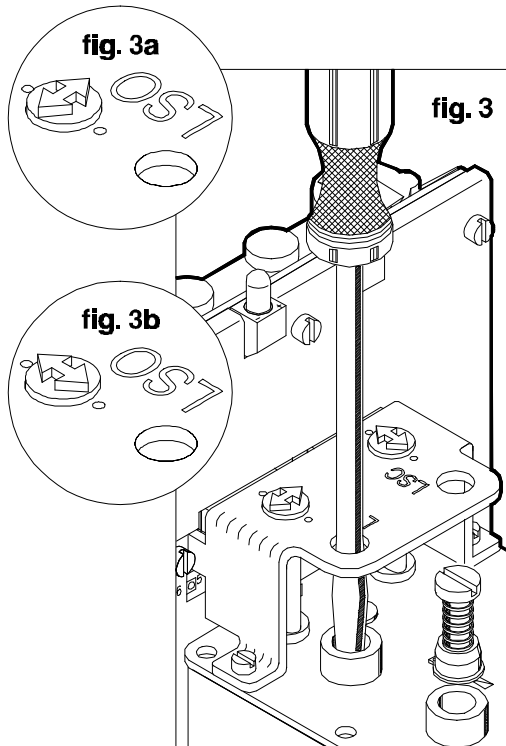
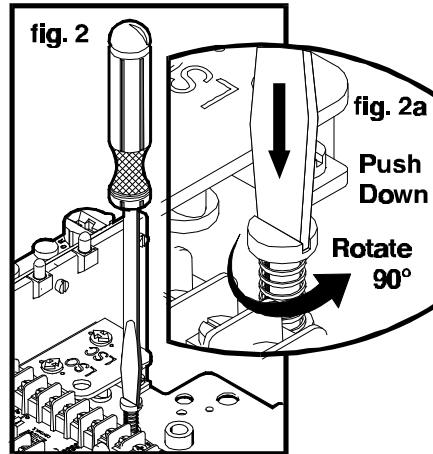
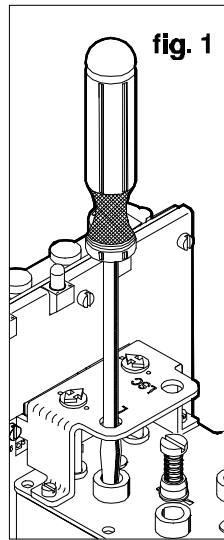

### SET (LSC) CLOSE LIMIT SWITCH

1. **Close valve**, using handwheel. During handwheel operation note rotation direction of screwdriver in LSC adjusting shaft. After valve is fully Closed, Open it three handwheel turns to allow for coast.
2. Repeat steps 2 through 5 of LSO setting instructions with screwdriver in LSC cavity.

**Important: "jiggle" adjusting shafts.**

### TO SET INTERMEDIATE SWITCH (LSA OR LSB), if included.

1. Open Valve to desired position, then repeat steps 2 thru 5 of LSO.

**Important: "jiggle" adjusting shafts.**

### TORQUE SEATED VALVES

If valve is a torque seated valve, and the geared limit contacts are used for indication only, the LSC switch should be set several handwheel turns ahead of torque switch contact action. This gives proper valve position Lamp indication in spite of minor position variations which might occur due to torque seating.

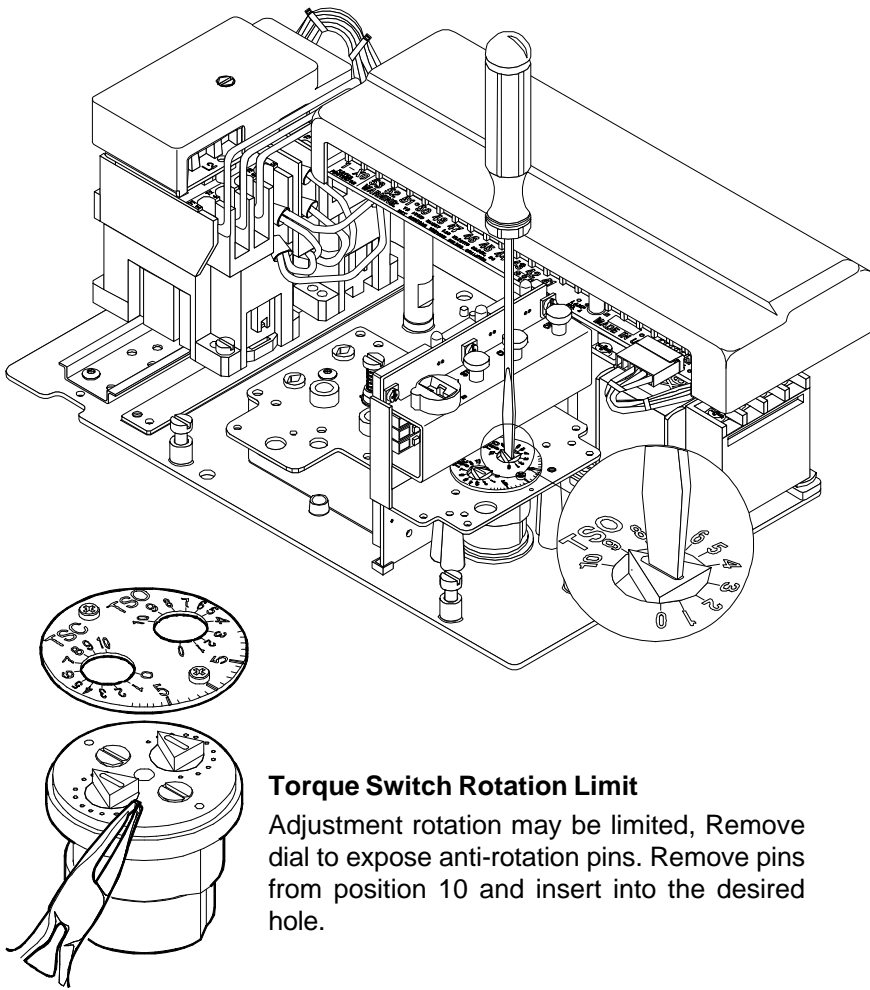

**Torque Switch Rotation Limit**

Adjustment rotation may be limited, Remove dial to expose anti-rotation pins. Remove pins from position 10 and insert into the desired hole.

**TORQUE SWITCH CALIBRATION**  
**To set Close Torque Switch (TSC)**

- a) Close valve using handwheel. Set valve to the desired torque. Observe rotating dial for number that corresponds to desired Close Torque.
- b) Insert screwdriver in TSC slot. Press down to disengage and turn arrow to setting determined in a). Release at this point and it will re-engage and remain set.
- c) Back the valve away from Close position and reseat by handwheel to verify torque trip point is at desired setting. The trip point of switch is a distinctive click as it breaks contact.
- d) **DANGER:**  
**REVERSE POWER VOLTAGE PHASING REMOVES TORQUE SWITCH PROTECTION FROM THE REVERSING CONTACTOR COIL CIRCUITS. VALVE DAMAGE COULD OCCUR.** If phasing has not been checked, do so before proceeding. Back valve away from Close position with handwheel and test torque electrically, using Close controls. Readjust as required.

**To Set Open Torque Switch (TSO)**

- a) Follow procedure as for TSC at TSO dial.

**Multi-turn Actuators**

Multi-turn top-mounted and side-mount bevel gear actuators require use of Gear Reduction Assembly part no. 84055-0000 for Mechanical Dial Position Indication MDPI and 1-turn Pot. N-number replaces -0000 to complete part no. For 1-turn Pot only *without* Dial Indication part no. is 84117-0000. Refer to EIM JOB SPEC SHEET for MDPI furnished.

MDPI *Mechanical Dial Position Indication* is a gear reduction assembly to convert multi-turn valve stem nut turns to 270 degrees (.75 turn) for viewing position indication arrow thru glass window on actuator electric switch compartment cover. Point of rotation reference has been designated as **N-number**. N is the total number of electric actuator 12-tooth gear limit spring-load pinion rotations for full valve stroke.

**Calibration**

MDPI & POT Drive is calibrated after LSC and LSO are properly set (Pg. 4). Move valve to Close position. Manually rotate MDPI arrow to indicate Close. Calibration is now complete. Open valve to check that MDPI arrow goes to Open, indicating that N is correct for full valve travel. Potentiometer, if included, has been calibrated. Mechanical dial travel is 270°. Approximately 5% of total Pot resistance is left on each end for total valve travel.

**Quarter-Turn Model P, Q, R & M**

Top-mount P, Q and R and several models of M/MG's side-mount do not require MDPI gear reduction assembly for 1-turn Pot. If multi-turn Pot is required, EIM JOB SPEC SHEET will list 84131-0000 or the correct assembly. Spec Sheet will list, (1) Pot clutch gear, (2) Pot input gear and (3) potentiometer.

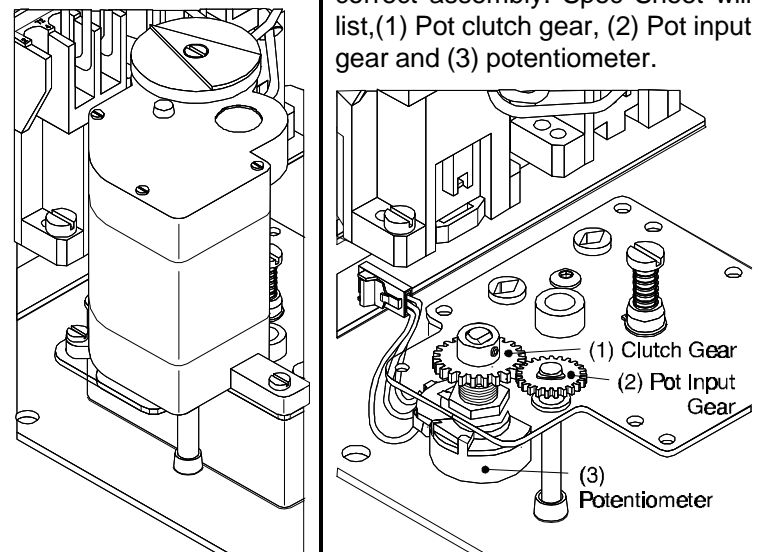

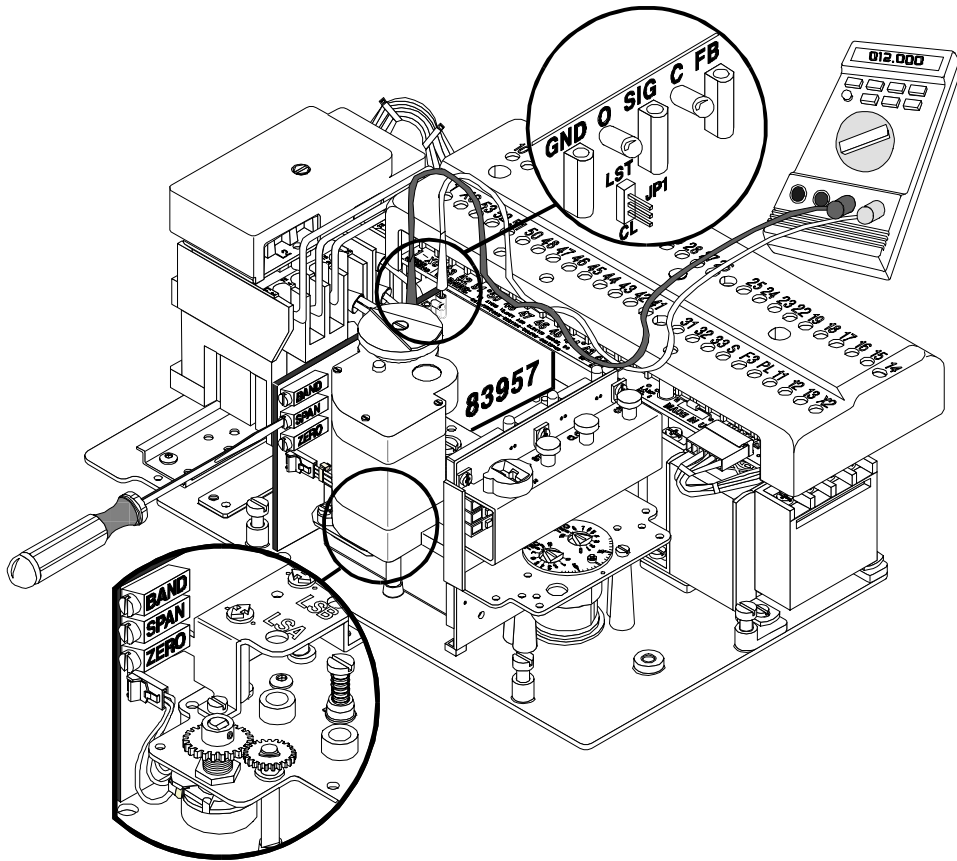

## Futronic II 83957

83957-1 (600 starts per hour maximum) or 83957-2 (100 starts per hour) module controls valve by comparing two inputs (the desired position from process controller or computer and actual valve feedback position). If the two are within **BAND**, valve will not move. When the setpoint moves outside the **BAND**, valve moves in the direction to make control signal and valve feedback position inputs balance.

## Calibration

After field wiring is complete, position limit switches have been set (Pg 4) and Pot adjustment on (Pg 5); proceed.

1. Voltmeter probes (+) in **Red (FB)** test point and (-) in **Black (GND)** test point.
2. Close valve: Meter should read **1 volt DC**. If it does not adjust **ZERO**.
3. Open valve: Meter should read **5 volts DC**. If it does not adjust **SPAN**.
4. Repeat steps 2 and 3 until no re-adjustment is necessary.
5. After a command signal has been connected, adjust **BAND** so valve moves to desired setpoint. **Delay**: 83957-1 has a six (6)\* second fixed delay preventing actuator from instantaneously responding to another signal. This allows reversing contactor to respond at 600 starts per hour maximum.

**Note:** Jumper **JP1** is factory set: See Job Spec Sheet for **JPI** position. Loss of 4-20 mA control signal will cause valve to (1) **LST** (last position will not move) or 2) **CL** valve will close. **JPI** jumper plug may be field changed.

**TIP:** To measure **BAND**, place Voltmeter (-) Probe in **Green (SIG)** test point and (+) probe in **Red (FB)** test point. Move valve using Handwheel. Observe reading when valve repositions. (**BAND** adjustment is  $\pm 1\%$  to  $7\%$ .)

\* 83957-2 has a thirty (30) second delay for 100 starts per hour maximum.

**Note 1)** Feedback Pot may be mounted on MDPI (Multi-turn valves) or mounted on gear cover (1/4 Turn valves).

# M2CP WIRING DIAGRAM SYMBOLS

Refer to EIM JOB SPEC SHEET and EIM WIRING DIAGRAM for components furnished.

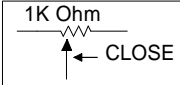

**POTENTIOMETER**  
Potentiometer slider is geared to Valve Position and "in-step" at all times

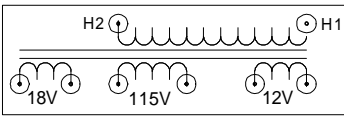

**TRANSFORMER**  
Outputs: 120, 12 and 18Vac



**PILOT LAMPS - LED INDICATORS**  
Actuated by position limit switches

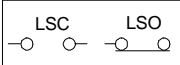

**POSITION LIMIT SWITCH**  
LSC shows open. LSO shown made.

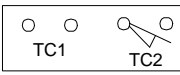

**TORQUE LIMIT SWITCHES**  
N.C. Double Break Contacts Open when overload occurs. N.O. contacts make.



**FUSE**



**PUSHBUTTONS N.C.**  
Momentary N.C. Contact

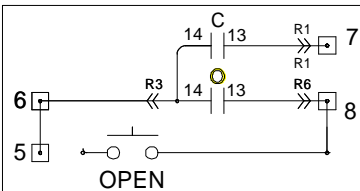

**PUSHBUTTONS N.O.**  
Momentary N.O. contacts connects control voltage to reversing contactor coils. Seal-in contacts C and O (14,13) on contactor allow travel without continued holding down of pushbutton.

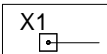

**TERMINAL POINTS**  
Factory wired by EIM



**CIRCUIT PLUG & RECEPTACLE**

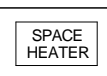

**SPACE HEATER**  
Heater in Switch  
Compartment is standard

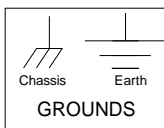

**GROUND**

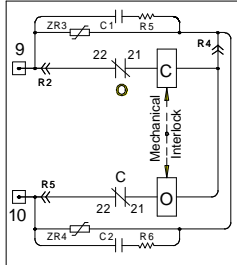

**REVERSING CONTACTOR**  
Showing Open and Close coils, Mechanical Interlock, and Electrical Interlock Contacts O (21, 22) & C (21, 22)

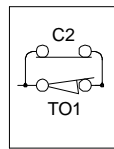

**NUISANCE TRIP**  
To prevent (TSO) contact tripping when valve has been jammed closed - LSC contact allows valve to open slightly. Contact then open, ensuring torque protection for remaining travel

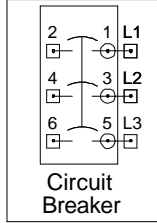

**Circuit Breaker**

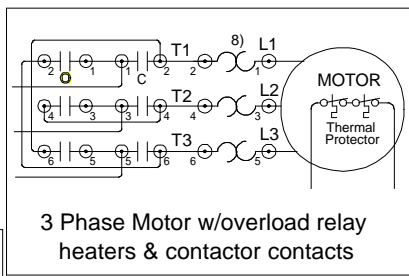

**3 Phase Motor w/overload relay heaters & contactor contacts**

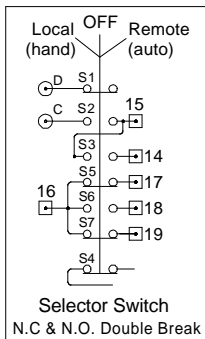

**Selector Switch**  
N.C & N.O. Double Break

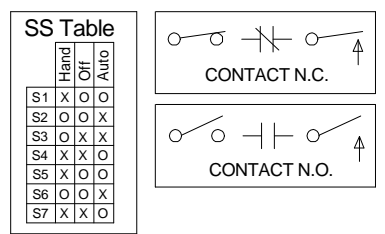

	Hand	Off	Auto
S1	X	O	O
S2	O	X	X
S3	O	X	X
S4	X	X	O
S5	X	O	O
S6	O	O	X
S7	X	X	O

**CONTACT N.C.**

**CONTACT N.O.**

## TROUBLE SHOOTING

SYMPTOM	PROBABLE CAUSE	CORRECTIVE ACTION
Motor will not Run	Blown Control Fuse Open in Control Circuit Insulation Resistance Breakdown in Motor	Check Fuse and Replace as necessary Refer to appropriate wiring diagram and check for continuity Perform Megger Test
No Power available to Actuator	Tripped Circuit Breaker	Reset Circuit Breaker
Handwheel Hard to Turn	Valve Stem improperly Lubricated Actuator Lubrication has broken down Valve packing gland too tight Drive Sleeve Bearing Failure Jammed Valve	Lubricate with Grease Clean out old grease and replace with recommended lubricant Loosen packing gland nuts as necessary Replace Bearing Refer to Valve Maintenance
Valve only opens or closes partially with motor	Torque Switch Setting too low Limit Switch Improperly Set	Check Setting and Reset if necessary Check Switch Actuation and recalibrate if necessary
Torque switch is properly set, but actuator Torque's out in mid-travel, open or closed direction	Damaged or bent valve stem Valve packing too tight Jammed Valve (obstruction in line)	Refer to Valve Maintenance Refer to Valve Maintenance Refer to Valve Maintenance
Handwheel will not operate valve	Handwheel shaft bearing assembly malfunction Sheared gear key or Stripped Gearing PS Shifter Position or Malfunction Broken Handwheel Shaft Broken Valve Stem or Stripped Stem Nut	Repair or replace as necessary Replace as necessary Replace Gear(s) Repair or replace as necessary Repair or replace as necessary
Motor runs but will not operate the valve	Motor Bearing Assembly Malfunction Sheared gear key (fastener pin) Stripped Gearing Broken Valve Stem or Stripped Stem Nut PS shifter position or malfunction	Repair or replace as necessary Replace Replace Repair or replace as necessary Replace PS Assembly
Moisture in Electrical Enclosure	Leakage through Conduit Entry  Electrical Enclosure is not properly sealed Space Heater Inoperable	Install an approved Seal-off or re-route conduit to enter Enclosure from the bottom of enclosure Inspect and replace O-ring if necessary Check Circuit continuity for Heater
Gear (Oil) in Electrical Enclosures	Pressure Relief Fitting not installed Bad Seal on T/L or G/L Assembly	Install Pressure Relief Fitting Replace Stat-O-Seals or O-Rings Rotate Actuator Mounting