

REOTEMP[®]

INSTRUMENTS

FOOD & LIFE SCIENCE INSTRUMENTS



WHY REOTEMP?



Customer Support

Direct access to our friendly and knowledgeable inside sales team, product managers, engineers, and product specialists.



Online Product Configurators

Our online product configurators are powerful tools that make specifying temperature and pressure instrumentation quick & easy. Now you can create part #s, see list pricing, & GENERATE CUSTOM ENGINEERING DRAWINGS IN SECONDS!



5-7 Day Standard Lead Time



Expedites Available

Product	STD	Expedite
RTD Head Assemblies	5-7 Days	1 Day
Bimetal Thermometers	3-5 Days	1 Day
Diaphragm Seals	5 Days	Same Day
Pressure Gauges	5 Days	Same Day
ReoClick™	10 Days	3 Days
ReoCube™	10 Days	3 Days
Slimline™	10 Days	3 Days
Thermowells	Stock-10 Days	Same Day-3 Days



Hi-Vibe™ is an optional feature on many of our RTD sensors. It's a proprietary sensor design that significantly improves lifespan and helps to maintain calibration in high vibration environments.



Hi-Accuracy™ is an optional feature on many of our RTD sensors. REOTEMP uses high-end fixed point calibration cells to determine precise coefficients for the sensor you purchase. You will later input these values into your transmitter. Once the precision coefficients are entered, your sensor will be roughly 5 times more accurate!



REOTEMP is a globally recognized ISO 9001:2008 manufacturer.

SANITARY SLIMLINE™

REOTEMP's SlimLine™ Sanitary Temperature sensor is a compact, rugged sensor perfectly suited to applications where space is limited. Available with or without a transmitter, the fully sealed design keeps out any water, liquids, or contaminants. It's perfect for applications where the sensor is exposed to the elements or equipment is washed down.

- Minimal Installation Space Required
- High Vibration & Shock Resistance
- Hermetically Sealed (NEMA 7, IP67)
- All-Welded 316SS Construction



Sealed Cable



M12 Connector

RTW 4-20 mA
Transmitter with
Sealed Cable

4-20 mA



RDW Sealed Cable
with Ohm Output

RTP 4-20 mA
Transmitter with M12
Quick Connect Plug

4-20 mA

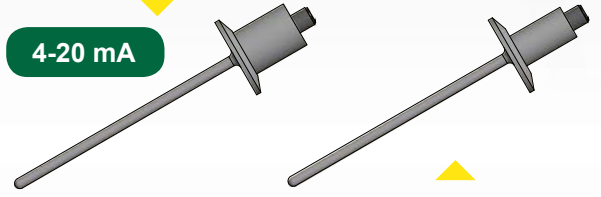

RDP with M12 Quick
Connect Plug with
Ohm Output

Wire Out & Plug Assemblies Without Transmitter

RDP M12 Plug assemblies allow for a quick and easy connection of the process wiring. Choice of the mating connector with or without attached wiring available.

RDW Sealed Cable assemblies allow you to wire directly to your PLC or transmitter. These units come standard with a nylon relief spring for added protection of the extension wires.



REOCLICK™

Patent
Pending



RCP REOCLICK
Removable element
with M12 Plug

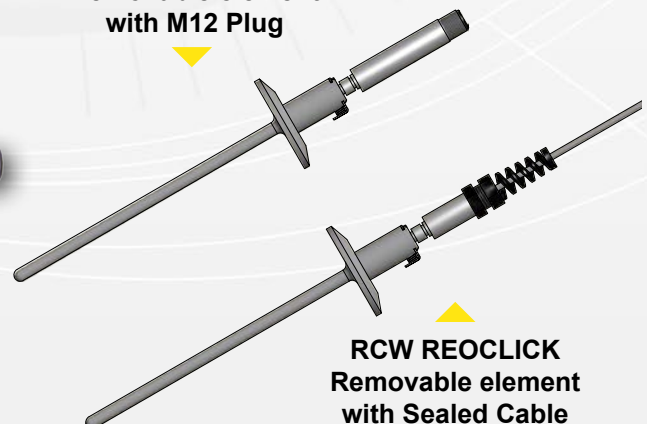

RCW REOCLICK
Removable element
with Sealed Cable

- Disconnect/re-connect temperature sensor with the click of a button.
- Sealed sensor can be placed directly in a calibration bath.
- Maintains process pressure when disconnected.

RTD HEAD ASSEMBLIES

REOTEMP's Sanitary RTDs are designed for temperature sensing in pharmaceutical, biotech, food, dairy, beverage and other applications where sensor corrosion and product contamination are critical factors.

- Ideal for CIP (clean-in-place) or SIP
- All Wetted Parts Highly Polished to Exceed 3-A Requirements
- Tri-Clamp® Design
- 3-A Certificate Included with Each Product

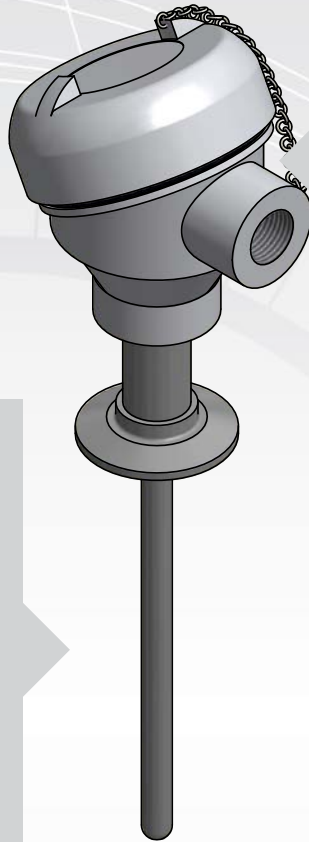

RTD Head Assemblies Offer a Variety of Stem and Termination Options

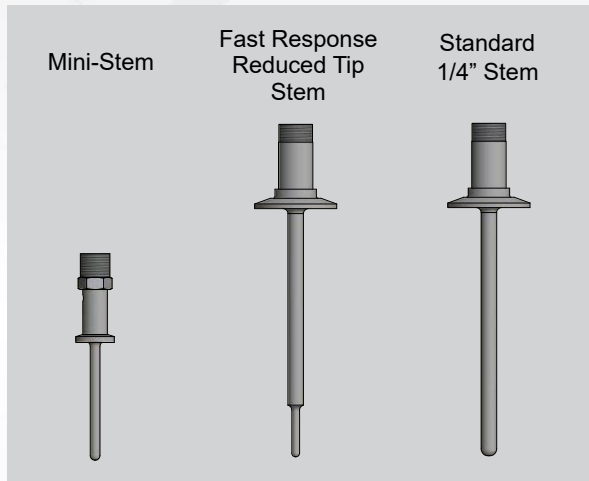

CUSTOM SOLUTIONS

ReoCube™

REOTEMP's ReoCube™ Isolation Bottles were developed to monitor the temperature of ultra low freezers or refrigerators. By submerging the temperature sensor(s) in liquid, the ReoCube™ ensures the temperature readings will not be thrown off when the freezer door is opened and ambient air rushes in.



Ultra-thin Cryogenic Flexible Probe

A Biotech customer required a probe with an extremely small diameter (0.050"), nearly instant response time and a flexible stem to monitor skin graft tissue in a cryogenic environment. Previous competitive probes were not flexible enough and damaged the temperature element. REOTEMP's engineering team designed a new probe within 3 weeks and with nearly instant response times.



"The probes were outstanding! I had excellent results in the first run with your newly designed probe!"
- Manufacturing Support Engineer

SANITARY THERMOMETERS



- Designed for Insertion into a Sanitary Process when a Thermowell is not Specified
- 3-A Certification Comes Standard
- Hermetically Sealed
- Liquid Fillable for Vibration
- 5 Year Warranty



Certified



Fillable



Custom Logo



Dials



ASME
B40.100

SANITARY PRESSURE



- Specifically Designed to Exceed Demanding 3-A Requirements
- All Welded 316SS Tube, Socket, Seal and Diaphragm
- Ideal for Clean-in-Place or Equipment Washdown
- Models Available for Autoclaving and Pulsation Service



Certified



Fillable



Custom Logo



Dials



ASME
B40.100

DIAL CUSTOMIZATION



Color Band

Color Pie

Custom Logo

Available on mechanical temperature and pressure gauges.

THERMOWELLS

- Remove an Instrument without Dropping Pressure or Losing the Contents of the Process
- Recommended for Pressurized Systems
- Easy-to-clean Ra 32 or Better Surface Finish
- Customizable to Your Process with a Variety of Stem, Bore and Material Options



Certificate
Included



TRANSMITTER SEAL ASSEMBLIES

REOTEMP can assemble a diaphragm seal system to virtually any make or model transmitter. Every transmitter mount includes features to ensure superior performance and durability for every assembly. REOTEMP also offers repair, refurbishment or replacement of used transmitters with remote seals.

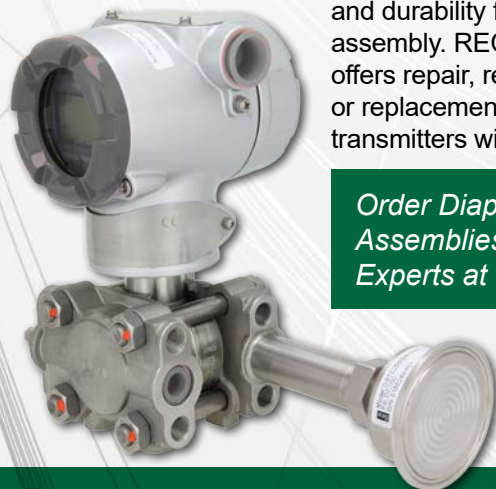

Order Diaphragm Seal Assemblies from the Experts at REOTEMP

PRESSURE TRANSMITTER & SWITCH



- Local Display with Switching Output and Analog Output (mA or Vdc)
- 316 Stainless Steel Wetted Parts
- Available with or without Sanitary Tri-Clamp Fitting
- M12 Quick Connector Plug



- IP67 Washdown Cover Option

HAND HELD TEMPERATURE PROBE



REOTEMP's Hand Held Multi-purpose Thermometer is a high accuracy thermometer used to spot check various process media commonly found in the brewing and food & beverage industries. It has a rugged all stainless steel construction and a built-in handle for ease of handling and extra protection.



- Easy to Read 4 Digit LCD Display
- High Accuracy Class A RTD (0.06%)
- Withstands Submersion in 1m of Water for Up to 30 minutes (IP67)
- Rugged All Stainless Steel Construction
- Fast Response Stem

SANITARY DIAPHRAGM SEALS



REOTEMP's Sanitary Diaphragm Seals are ideal for applications in the food and beverage, dairy, and pharmaceutical industries. REOTEMP will mount and fill a variety of instruments to sanitary seals including Digital Pressure Gauges, Transmitters, and Switches. All Sanitary Diaphragm Seal Assemblies manufactured by REOTEMP are 3-A Certified.



CALIBRATION & CERTIFICATION SERVICES



REOTEMP uses a combination of fixed point temperature calibration cells and fluid-filled calibration equipment to perform sensor calibrations from -196°C to 1,300°C. REOTEMP also offers pressure calibrations from inches of water up to 30,000 psi. Our friendly and knowledgeable calibration technicians will ensure your sensors have the accuracy required for your application.

- NIST-traceable Calibration Certificates
- 3-A Certificates and Material Traceability
- Mill Test Reports and PMI

REOTEMP

Address 10656 Roselle St.
San Diego, CA 92121

Phone +1 (858) 784-0710
Fax +1 (858) 784-0720
Email sales@reotemp.com



Distributed by: