

# FABRICAST VALVE

Knife Gate Valves & Custom Fabrication



**360-425-0306**

**Toll Free: 1-877-264-2503**

**Fax: 360-425-0353**

**[www.knifegates.com](http://www.knifegates.com)**

**1061 Industrial Way  
Longview, WA 98632**





**Fabricast Valve Company**  
1061 Industrial Way, Longview, WA 98632  
**Toll-Free** 1-877-264-2503  
**Local** (360) 425-0306 **Fax** (360) 425-0353  
www.knifegates.com  
sales@fabricastvalve.com



# FIG 40

FIG 40

Fabricast Valve

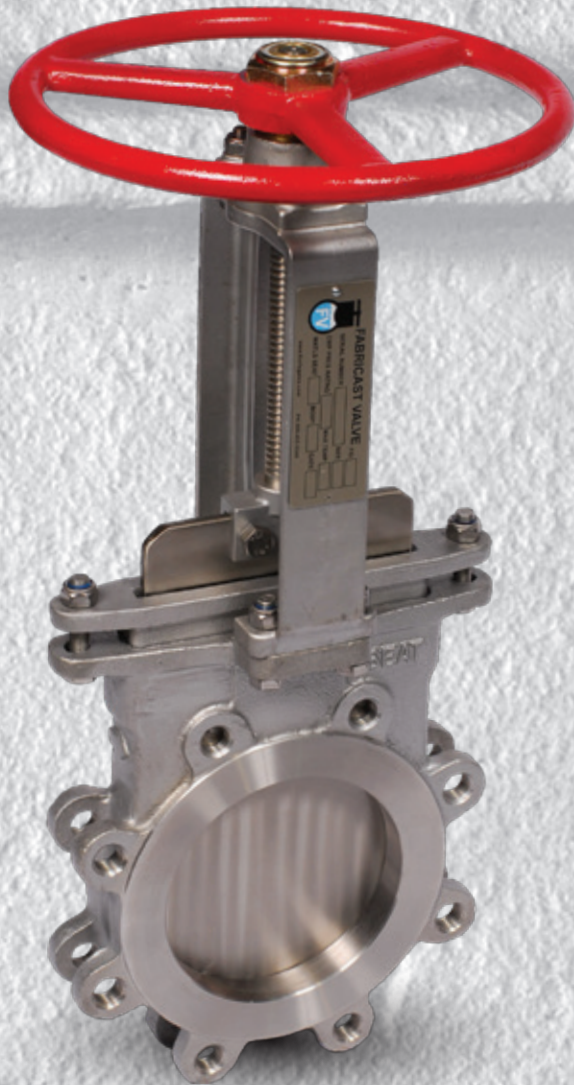

The Fabricast FIG 40 is a metal seated, uni-directional knife gate valve. Designed and tested to MSS SP81 and ASME B16.5 specifications.

## Features

- Heavy Duty Cast CF8 304, CF8M T316 or CG8M T317 body and packing gland. Cast CF8 T304 yoke, stemnut retainer and gate clevis.
- Full Port.
- 150 Psi Cwp Rated.
- Precision Cnc Machined Valve Body And Stem.
- ASTM A 240 304, 316, and 317 Stainless Steel gate fully machined, beveled and surface ground. All edges are chamfered to extend packing life and to provide a superior atmospheric seal.
- 14" and larger valves are supplied with a ball bearing yoke bushing to reduce handwheel rimpull.
- Braided Teflon Synthetic Packing is standard 3-11 PH rating, 500°F.
- Cast WCB Steel handwheel (weldable)
- Easily adapted to Air Cylinder, Hydraulic Cylinder, Bevel Gear, Lever or Electric Motor Operator (no welding required).

## Options

- O-ring Seat - Buna N 200 Deg F, Epdm 300 Deg F, Hdpe/uhmwpe 200 Deg F, Fkm/viton - 400 Deg F. Other - Contact Factory
- Other Alloys - 310, 316, 317I, Duplex 2205, 2507,904I, Hastelloy, Titanium Other - Contact Factory
- Mechanical Lockouts - Manual And Actuated Valves
- Osha Gate Guard
- Pneumatic, Hydraulic And Spring Cylinder, Electric Motor Operator, 3:1 And 4:1 Bevel Gear Operator, Chainwheel, Stem Extensions, Lever Operator
- Packings - Ptfе, Graphite, Kevlar, Food Grade, Other - Contact Factory
- Purge / Flushing Ports
- Limit / Proximity Switches, Solenoid Valves, Positioners, Air Sets, Speed Controls, Exhaust Mufflers, Air Tank Failsafe Systems, Air Boosters
- V Port Inserts For Flow Control
- Deflector Cones For Abrasive Service
- Ni-resist Alloy Stemnut
- Live Loaded Packing System
- Specialty Gate Coatings
- Hardsurfacing For Abrasive Service
- Backing Ring For Reverse Flow Or Horizontal Valve Orientation
- High Pressure
- High Temperature

## Previous Model FV-150-MM

Optional Operators see [www.knifegates.com](http://www.knifegates.com) for details



Cylinder



Bevel Gear



Electric Motor



Chain Wheel



Lever



**Fabricast Valve Company**  
 1061 Industrial Way, Longview, WA 98632  
**Toll-Free 1-877-264-2503**  
**Local (360) 425-0306 Fax (360) 425-0353**  
 www.knifegates.com  
 sales@fabricastvalve.com

# FIG 40

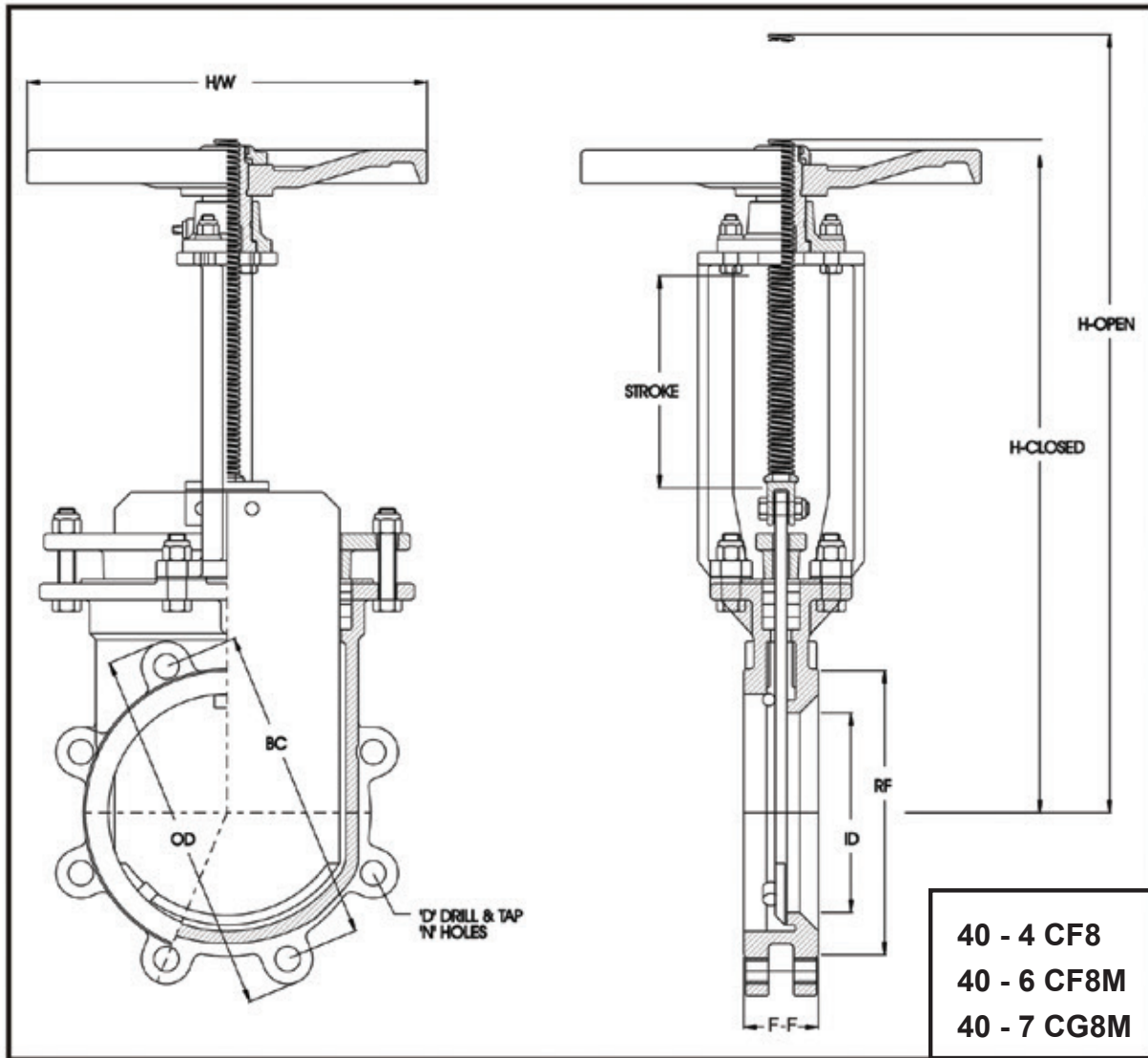

**40 - 4 CF8**  
**40 - 6 CF8M**  
**40 - 7 CG8M**

Size		2"	3"	4"	6"	8"	10"	12"	14"	16"	18"	20"	24"	30"	36"
Face to Face	<b>F-F</b>	1 <sup>7</sup> / <sub>8</sub> "	2"	2"	2- <sup>1</sup> / <sub>4</sub> "	2- <sup>3</sup> / <sub>4</sub> "	2- <sup>3</sup> / <sub>4</sub> "	3"	3"	3- <sup>1</sup> / <sub>2</sub> "	3- <sup>1</sup> / <sub>2</sub> "	4- <sup>1</sup> / <sub>2</sub> "	4- <sup>1</sup> / <sub>2</sub> "	5 <sup>3</sup> / <sub>8</sub> "	6"
Flange OD	<b>OD</b>	6"	7- <sup>1</sup> / <sub>2</sub> "	9"	11"	13- <sup>1</sup> / <sub>2</sub> "	16"	19"	21"	23- <sup>1</sup> / <sub>2</sub> "	25"	27- <sup>1</sup> / <sub>2</sub> "	32"	38- <sup>3</sup> / <sub>4</sub> "	46"
Bolt Circle	<b>BC</b>	4- <sup>3</sup> / <sub>4</sub> "	6"	7- <sup>1</sup> / <sub>2</sub> "	9- <sup>1</sup> / <sub>2</sub> "	11- <sup>3</sup> / <sub>4</sub> "	14- <sup>1</sup> / <sub>4</sub> "	17"	18- <sup>3</sup> / <sub>4</sub> "	21- <sup>1</sup> / <sub>4</sub> "	22- <sup>3</sup> / <sub>4</sub> "	25"	29- <sup>1</sup> / <sub>2</sub> "	36"	42- <sup>3</sup> / <sub>4</sub> "
Inside Diameter	<b>ID</b>	2"	3"	4"	6"	8"	10"	12"	13- <sup>5</sup> / <sub>8</sub> "	15- <sup>1</sup> / <sub>2</sub> "	17- <sup>1</sup> / <sub>2</sub> "	19- <sup>1</sup> / <sub>2</sub> "	23- <sup>3</sup> / <sub>8</sub> "	29- <sup>1</sup> / <sub>4</sub> "	35 <sup>3</sup> / <sub>8</sub> "
Number of Holes	<b>N</b>	4	4	8	8	8	12	12	12	16	16	20	20	28	32
Hole D&T Size	<b>D</b>	5 <sup>8</sup> / <sub>16</sub> "-11	5 <sup>8</sup> / <sub>16</sub> "-11	5 <sup>8</sup> / <sub>16</sub> "-11	3 <sup>4</sup> / <sub>16</sub> "-10	3 <sup>4</sup> / <sub>16</sub> "-10	7 <sup>8</sup> / <sub>16</sub> "-9	7 <sup>8</sup> / <sub>16</sub> "-9	1"-8	1"-8	1- <sup>1</sup> / <sub>8</sub> "-7	1- <sup>1</sup> / <sub>8</sub> "-7	1- <sup>1</sup> / <sub>4</sub> "-7	1- <sup>1</sup> / <sub>4</sub> "-7	1 <sup>1</sup> / <sub>2</sub> "-6
C'L to Top Closed	<b>H-Closed</b>	13- <sup>5</sup> / <sub>8</sub> "	16"	17- <sup>3</sup> / <sub>4</sub> "	21- <sup>5</sup> / <sub>8</sub> "	26- <sup>3</sup> / <sub>4</sub> "	32- <sup>1</sup> / <sub>8</sub> "	36- <sup>3</sup> / <sub>8</sub> "	42"	46- <sup>3</sup> / <sub>4</sub> "	52- <sup>3</sup> / <sub>8</sub> "	49- <sup>3</sup> / <sub>4</sub> "	55- <sup>1</sup> / <sub>8</sub> "	80"	111- <sup>3</sup> / <sub>8</sub> "
C/L to Top Open	<b>H-OPEN</b>	16"	19- <sup>3</sup> / <sub>4</sub> "	21- <sup>5</sup> / <sub>8</sub> "	27- <sup>3</sup> / <sub>4</sub> "	34- <sup>3</sup> / <sub>4</sub> "	42- <sup>3</sup> / <sub>4</sub> "	48- <sup>5</sup> / <sub>8</sub> "	55- <sup>1</sup> / <sub>4</sub> "	63- <sup>1</sup> / <sub>8</sub> "	70- <sup>1</sup> / <sub>2</sub> "	69- <sup>3</sup> / <sub>4</sub> "	79- <sup>7</sup> / <sub>8</sub> "	114- <sup>1</sup> / <sub>4</sub> "	145- <sup>3</sup> / <sub>4</sub> "
Handwheel Dia.	<b>H/W</b>	8"	8"	8"	12"	12"	15"	15"	15"	20"	20"	20"	30"	18"	18"
Raised Face Diameter	<b>RF</b>	3- <sup>5</sup> / <sub>8</sub> "	5"	6- <sup>3</sup> / <sub>8</sub> "	8- <sup>1</sup> / <sub>2</sub> "	10- <sup>5</sup> / <sub>8</sub> "	12- <sup>3</sup> / <sub>4</sub> "	15"	16- <sup>1</sup> / <sub>4</sub> "	18- <sup>1</sup> / <sub>2</sub> "	21"	23"	27- <sup>1</sup> / <sub>4</sub> "	33 <sup>3</sup> / <sub>4</sub> "	40 <sup>1</sup> / <sub>4</sub> "
Weight (lbs.)		20	29	38	52	85	120	160	212	300	350	480	600	1136	2205

*Note: 30" and 36" cast valves with gear operator*

Fabricast Valve  
 Knife Gate Valves & Custom Fabrication / phone (360) 425-0306, fax (360) 425-0353



**Fabricast Valve Company**  
 1061 Industrial Way, Longview, WA 98632  
**Toll-Free 1-877-264-2503**  
**Local (360) 425-0306 Fax (360) 425-0353**  
 www.knifegates.com  
 sales@fabricastvalve.com

# Fabricast Valve

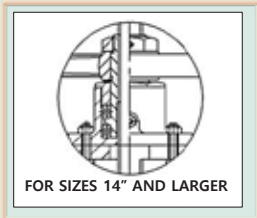
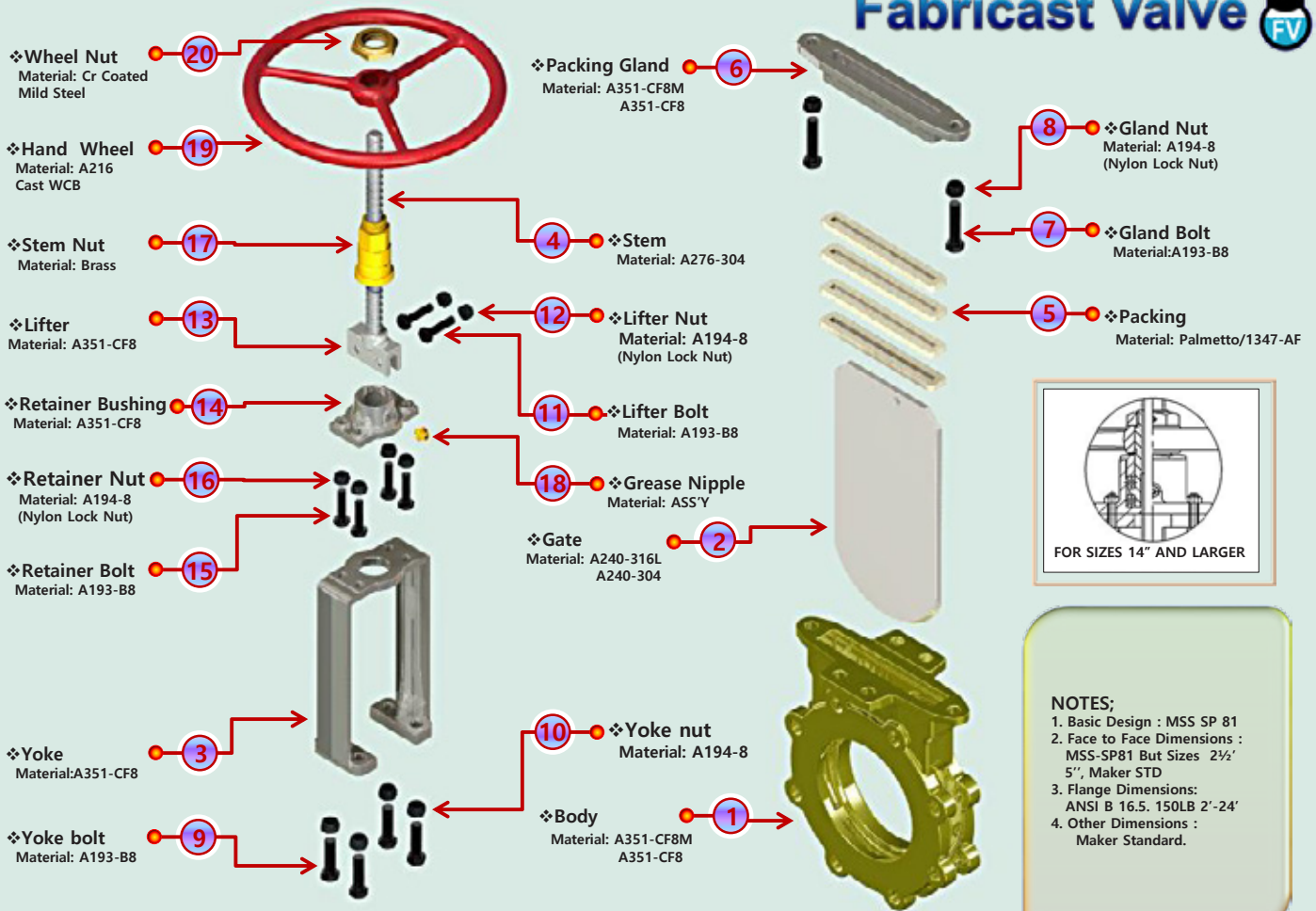

**NOTES;**

1. Basic Design : MSS SP 81
2. Face to Face Dimensions : MSS-SP81 But Sizes 2½' 5", Maker STD
3. Flange Dimensions: ANSI B 16.5, 150LB 2'-24'
4. Other Dimensions : Maker Standard.



**Fabricast Valve Company**  
 1061 Industrial Way, Longview, WA 98632  
**Toll-Free 1-877-264-2503**  
**Local (360) 425-0306 Fax (360) 425-0353**  
 www.knifegates.com  
 sales@fabricastvalve.com

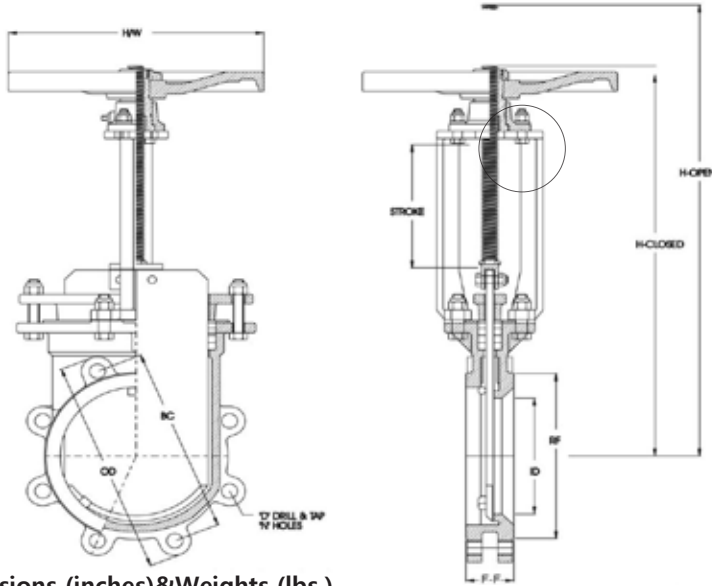

**Fabricast Valve** 

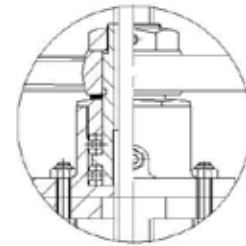

FOR SIZES 14" AND LARGER

30" & 36" COME  
 STANDARD WITH  
 GEAR OPERATOR

**Dimensions (inches)&Weights (lbs.)**

Size		2"	3"	4"	6"	8"	10"	12"	14"	16"	18"	20"	24"	30"	36"
Face to Face	F-F	1-7/8"	2"	2"	2-1/4"	2-3/4"	2-3/4"	3"	3"	3-1/2"	3-1/2"	4-1/2"	4-1/2"	5-3/16"	6"
Flange	OD	6"	7-1/2"	9"	11"	13-1/2"	16"	19"	21"	23-1/2"	25"	27-1/2"	32"	38-3/4"	46"
Bolt Circle	BC	4-3/4"	6"	7-1/2"	11-3/4"	9-1/2"	14-1/4"	17"	18-3/4"	21-1/4"	22-3/4"	25"	29-1/2"	36"	42-3/4"
Inside Diameter	ID	2"	3"	4"	6"	8"	10"	12"	13-5/8"	15-1/2"	17-1/2"	19-1/2"	23-3/8"	29-1/4"	35-3/16"
Number of Holes	N	4	4	8	8	8	12	12	12	16	16	20	20	28	32
Tap	D	5/8"-11	5/8"-11	5/8"-11	3/4"-10	3/4"-10	7/8"-9	1"-8	1"-8	1"-8	1-1/8"-7	1-1/8"-7	1-1/4"-7	1-1/4"-7	1-1/2"-6
C/L to Top Closed	H-C	13-5/8"	16"	17-3/4"	21-5/8"	26-3/4"	32-1/8"	36-3/8"	42"	46-3/4"	52-3/8"	76-1/4"	91-1/4"	80"	111-3/8"
C/L to Top Open	H-O	16"	19-3/4"	21-5/8"	27-3/4"	34-3/4"	42-3/4"	48-5/8"	55-1/4"	63-1/8"	70-1/2"	96-3/4"	116"	114-1/4"	145-3/4"
Handwheel Dia	H/W	8"	8"	8"	12"	12"	15"	15"	15"	20"	20"	20"	30"	18"	18"
Raised Face Dia	RF	3-5/8"	5"	6-3/16"	8-1/2"	10-5/8"	12-3/4"	15"	16-1/4"	18-1/2"	21"	23"	27-1/4"	33-3/4"	40-1/4"
Weight (lbs)		20	29	38	52	85	120	160	212	300	350	480	600	1136	2205



**Fabricast Valve Company**  
1061 Industrial Way, Longview, WA 98632  
Toll-Free 1-877-264-2503  
Local (360) 425-0306 Fax (360) 425-0353  
www.knifegates.com  
sales@fabricastvalve.com



# FIG 50

FIG 50

Fabricast Valve

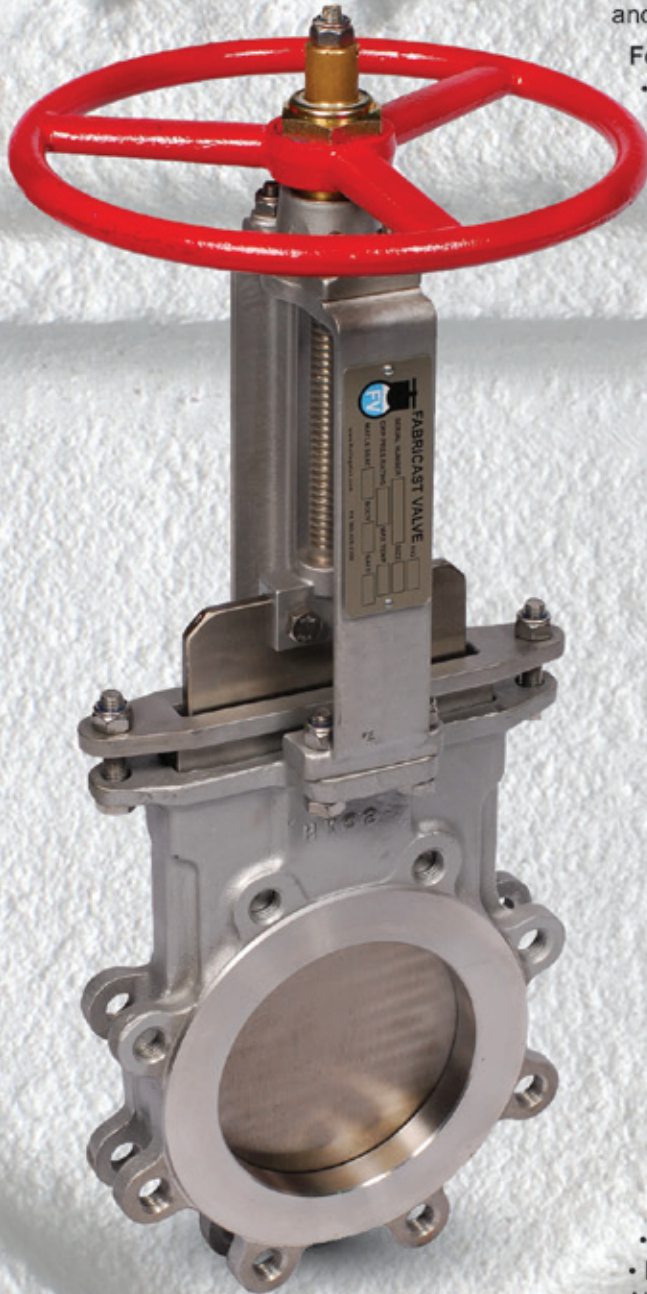

The Fabricast FIG 50 is a resilient (rubber) seated, perimeter sealed Bi-directional Knife Gate valve. Designed and tested to MSS SP81 and ASME B16.5 specifications.

### Features

- Heavy Duty Cast CF8 T304, CF8M T316 or CG8M T317 body and packing gland. Cast CF8 T304 yoke, stemnut retainer and gate clevis. Sizes larger than 36" are available in a fabricated and welded design.
- Full Port
- 150 PSI CWP Rated
- Precision CNC machined valve body and stem
- ASTM a 240 304, 316, 317 Stainless Steel gate fully machined and surface ground. All edges are chamfered to extend packing life and to provide a superior atmospheric seal.
- 14" and larger valves are supplied with a ball bearing yoke bushing to reduce handwheel rimpull
- Braided Teflon Synthetic Packing is standard 3-11 PH rating.
- BUNA N seat is standard 180 Deg. F.
- Locking fasteners are standard on all Fabricast valves
- Cast WCB Steel handwheel (weldable)
- Easily adapted to Air Cylinder, Hydraulic Cylinder, Bevel Gear, Lever or Electric Motor Operator (no welding required)

### Options

- Seat - EPDM 300 Deg F, FKM/VITON 400 Deg F, PTFE 500 Deg F, Other - Contact factory
- Other alloys - 316, 317I, Duplex 2205, 2507, 904L, Hastelloy, Titanium
- Other - Contact factory
- Mechanical lockouts - manual and actuated valves
- Osha gate guard
- Pneumatic, hydraulic and spring cylinder, electric motor operator, 3:1 and 4:1 bevel gear operator, chainwheel, stem extensions, lever operator.
- Packings - PTFE, Graphite, Kevlar, Food Grade, Other - Contact factory
- Purge / flushing ports
- Limit / proximity switches, solenoid valves, positioners, air sets, speed controls, exhaust mufflers, air tank failsafe systems, air boosters
- V port insert for flow control
- Deflector cones for abrasive service
- Ni-resist alloy stemnut
- Live loaded packing system
- Specialty gate coatings
- Hardsurfacing for abrasive service

### Previous Model FV-150-PS

Optional Operators see [www.knifegates.com](http://www.knifegates.com) for details



Cylinder



Bevel Gear



Electric Motor



Chain Wheel



Lever



**Fabricast Valve Company**  
 1061 Industrial Way, Longview, WA 98632  
 Toll-Free 1-877-264-2503  
 Local (360) 425-0306 Fax (360) 425-0353  
 www.knifegates.com  
 sales@fabricastvalve.com

# FIG 50

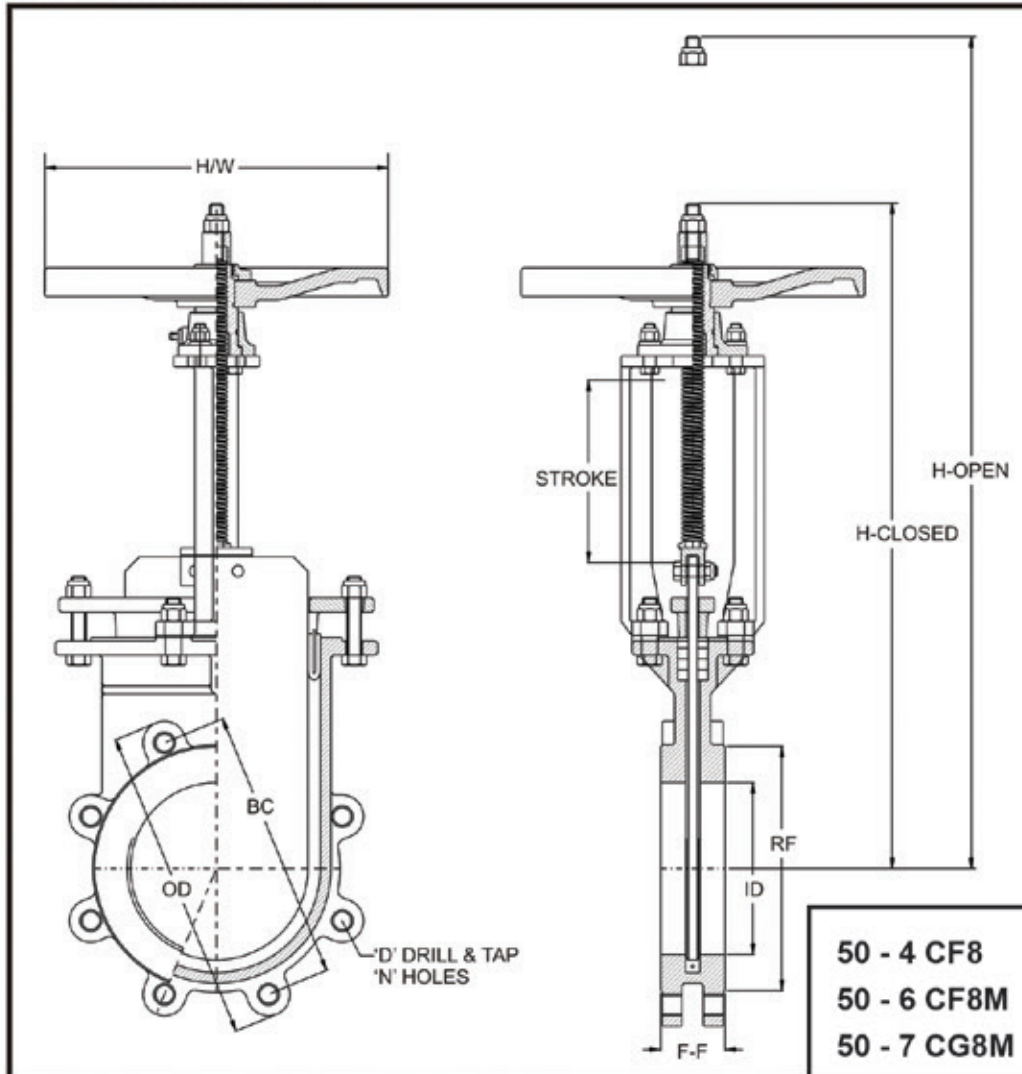

Size		2"	3"	4"	6"	8"	10"	12"	14"	16"	18"	20"	24"	30"	36"
Face to Face	F-F	1-7/8"	2"	2"	2-1/4"	2-3/4"	2-3/4"	3"	3"	3-1/2"	3-1/2"	4-1/2"	4-1/2"		
Flange OD	OD	6"	7-1/2"	9"	11"	13-1/2"	16"	19"	21"	23-1/2"	25"	27-1/2"	32"		
Bolt Circle	BC	4-3/4"	6"	7-1/2"	9-1/2"	11-3/4"	14-1/4"	17"	18-3/4"	21-1/4"	22-3/4"	25"	29-1/2"		
Inside Diameter	ID	2"	3"	4"	6"	8"	10"	12"	13/5-8"	15-1/2"	17-1/2"	19-1/2"	23-3/8"		
Number of Holes	N	4	4	8	8	8	12	12	12	16	16	20	20		
Hole D&T Size	D	5/8"-11	5/8"-11	5/8"-11	3/4"-10	3/4"-10	7/8"-9	7/8"-9	1"-8	1"-8	1-1/8"-7	1-1/8"-7	1-1/4"-7		
C'L to Top Closed	H-Closed	13-5/8"	16"	17-3/4"	21-5/8"	26-3/4"	32-1/8"	36-3/8"	42"	46-3/4"	52-3/8"	56"	62-7/8"		
C/L to Top Open	H-OPEN	16"	19-3/4"	21-5/8"	27-3/4"	34-3/4"	42-3/4"	48-5/8"	55-1/4"	63-1/8"	70-1/2"	75-5/8"	85-5/8"		
Handwheel Dia.	H/W	8"	8"	8"	12"	12"	15"	15"	15"	20"	20"	20"	30"		
Raised Face Diameter	RF	3-5/8"	5"	6-3/16"	8-1/2"	10-5/8"	12-3/4"	15"	16-1/4"	18-1/2"	21"	23"	27-1/4"		
Weight (lbs.)		20	29	38	52	85	120	160	212	300	350	480	600	1169	2425

**Fabricast Valve**  
 Knife Gate Valves & Custom Fabrication / phone (360) 425-0306, fax (360) 425-0353



**Fabricast Valve Company**  
1061 Industrial Way, Longview, WA 98632  
**Toll-Free** 1-877-264-2503  
**Local** (360) 425-0306 **Fax** (360) 425-0353  
www.knifegates.com  
sales@fabricastvalve.com

## Fabricast Valve

### FIGURE 50-PS RESILIENT SEATED KNIFE GATE VALVE

The Fabricast Valve FIG. 50-PS is a resilient (rubber) seated, perimeter sealed, knife gate valve featuring a cast stainless steel body, packing gland, and yoke. It is designed and tested to conform with MSS SP-81, and ASME B16.5 Class 150 specifications.

The heavy-duty cast body features a full-port I.D. and machined faces. It is designed to withstand up to 150 PSI of pressure as required by MSS SP-81.

As also required by this standard, the ground and machined stainless steel gate is designed to withstand pressures up to 150 PSI.

Our resilient/rubber seat provides a bi-directional, drip-tight seal across the gate for any pressure up to 150 PSI. It is flush with the bottom of the valve, making replacement quick and easy, and eliminating pockets to provide a smooth transition for the pipeline media.

The stainless steel stem resists corrosion, and is accompanied by a stainless steel stem nut retainer that protects the stem bushing from harsh environments, and reduces operating torque.

Our Teflon Synthetic Packing is rated standard with a Ph range of 3-11, and temperature rating up to 500° F.

Converting from the hand wheel operator to cylinder, bevel gear, or electric motor is easy and requires no additional welding.

Available in T304, T316, T317 Stainless Steel.

**Flanges match ANSI 150LB, PN10, TABLE "D", JIS 10kg Standard with all tapped holes.**

**PREVIOUS MODEL NAME FV 150-PS**

**FABRICAST VALVE**

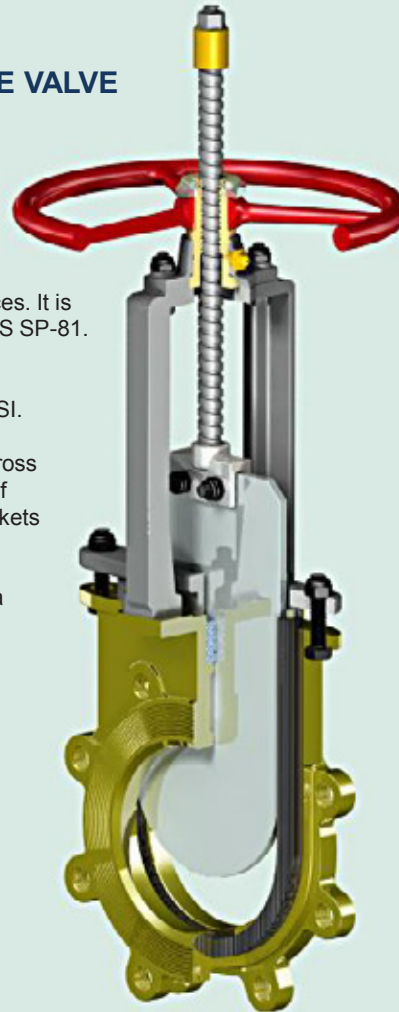

#### Optional Operators

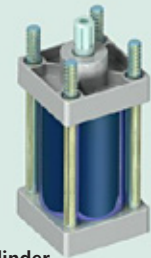

Cylinder



Lever



Electric

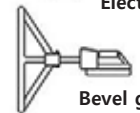

Bevel gear



Chain Wheel





**Fabricast Valve Company**  
 1061 Industrial Way, Longview, WA 98632  
**Toll-Free 1-877-264-2503**  
**Local (360) 425-0306 Fax (360) 425-0353**  
 www.knifegates.com  
 sales@fabricastvalve.com

# Fabricast Valve

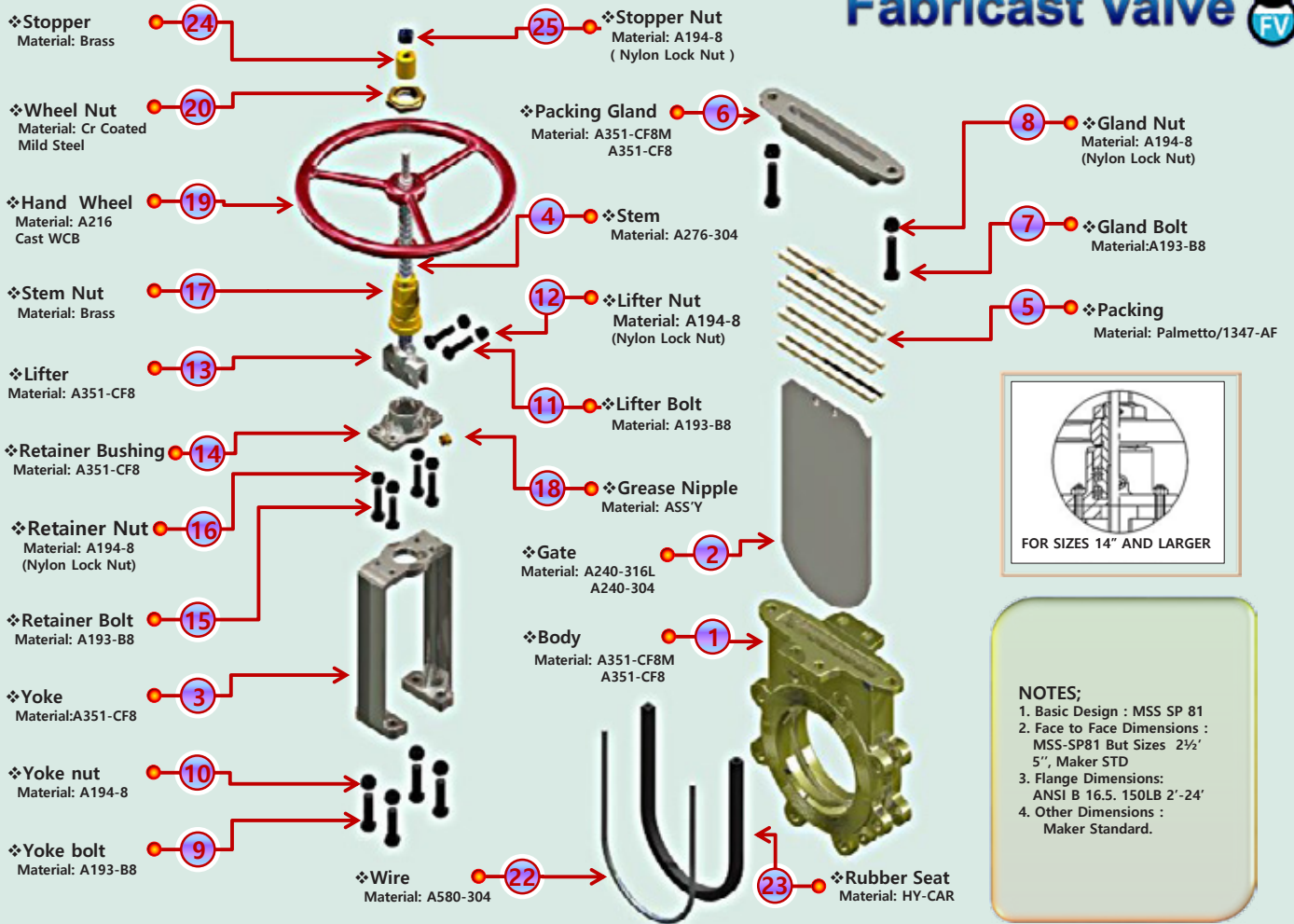



**Fabricast Valve Company**  
 1061 Industrial Way, Longview, WA 98632  
**Toll-Free 1-877-264-2503**  
**Local (360) 425-0306 Fax (360) 425-0353**  
 www.knifegates.com  
 sales@fabricastvalve.com

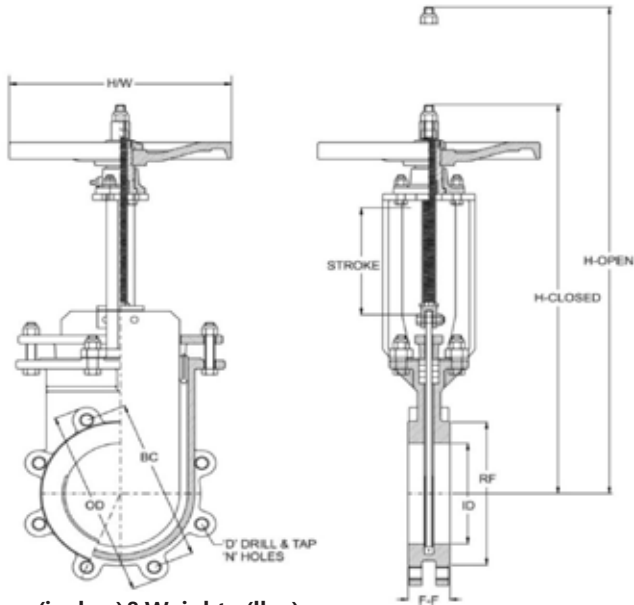

**Fabricast Valve** 

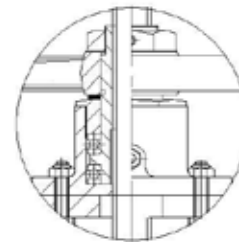

FOR SIZES 14" AND LARGER

30" & 36" COME  
 STANDARD WITH  
 GEAR OPERATOR

**Dimensions (inches)&Weights (lbs.)**

Size		2"	3"	4"	6"	8"	10"	12"	14"	16"	18"	20"	24"	30"	36"
Face to Face	F-F	1-7/8"	2"	2"	2-1/4"	2-3/4"	2-3/4"	3"	3"	3-1/2"	3-1/2"	4-1/2"	4-1/2"	5-3/16"	6"
Flange	OD	6"	7-1/2"	9"	11"	13-1/2"	16"	19"	21"	23-1/2"	25"	27-1/2"	32"	38-3/4"	46"
Bolt Circle	BC	4-3/4"	6"	7-1/2"	11-3/4"	9-1/2"	14-1/4"	17"	18-3/4"	21-1/4"	22-3/4"	25"	29-1/2"	36"	42-3/4"
Inside Diameter	ID	2"	3"	4"	6"	8"	10"	12"	13-5/8"	15-1/2"	17-1/2"	19-1/2"	23-3/8"	29-1/4"	35-3/16"
Number of Holes	N	4	4	8	8	8	12	12	12	16	16	20	20	28	32
Tap	D	5/8"-11	5/8"-11	5/8"-11	3/4"-10	3/4"-10	7/8"-9	1"-8	1"-8	1"-8	1-1/8"-7	1-1/8"-7	1-1/4"-7	1-1/4"-7	1-1/2"-6
C/L to Top Closed	H-C	13-5/8"	16"	17-3/4"	21-5/8"	26-3/4"	32-1/8"	36-3/8"	42"	46-3/4"	52-3/8"	76-1/4"	91-1/4"	80"	111-3/8"
C/L to Top Open	H-O	16"	19-3/4"	21-5/8"	27-4/3"	34-3/4"	42-3/4"	48-5/8"	55-1/4"	63-1/8"	70-1/2"	96-3/4"	116"	114-1/4"	145-3/4"
Handwheel Dia	H/W	8"	8"	8"	12"	12"	15"	15"	15"	20"	20"	20"	30"	18"	18"
Raised Face Dia	RF	3-5/8"	5"	6-3/16"	8-1/2"	10-5/8"	12-3/4"	15"	16-1/4"	18-1/2"	21"	23"	27-1/4"	33-3/4"	40-1/4"
Weight (lbs)		20	29	38	52	85	120	160	212	300	350	480	600	1136	2205



**Fabricast Valve Company**  
 1061 Industrial Way, Longview, WA 98632  
**Toll-Free 1-877-264-2503**  
**Local (360) 425-0306 Fax (360) 425-0353**  
 www.knifegates.com  
 sales@fabricastvalve.com



# FIG 61

FIG 61

Fabricast Valve

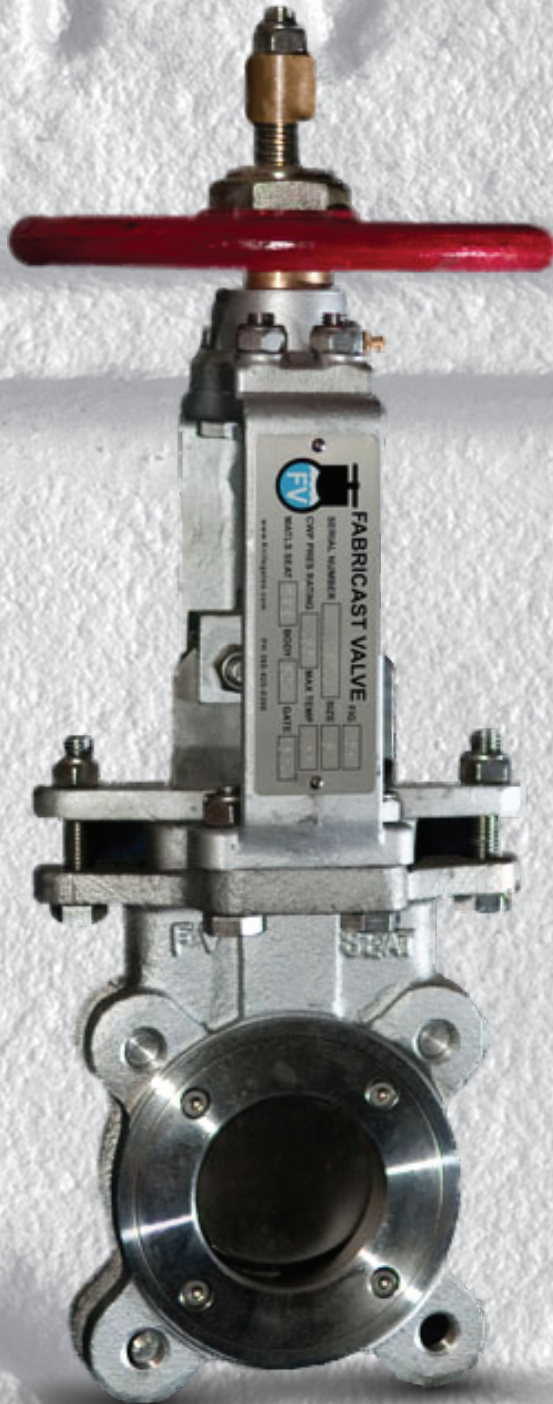

The Fabricast FIG 61 is a unique high performance knife gate valve design utilizing dual replaceable polymer seals. Designed and tested to MSS SP81 and ASME B16.5 specifications.

### Features

- Dual Polymer seals (Teflon is Standard) fitted on 316 Stainless Steel retaining rings along with robust o-rings (EPDM Is Standard 300 Deg F.) that provides resiliency and seal loading. The o-rings also seal the machined retainer ring cavity in the valve body to eliminate external leakage. Seals, o-rings and retainer rings are easily replaced either in the shop or in the field.
- Full Port
- Bi-directional Drip Tight Shutoff.
- 150 Psi CWP Rating.
- Heavy Duty Cast CF8M 316 Stainless Steel Body and Packing Gland.
- Valve body, retaining rings, stem and Polymer seals are precision CNC machined.
- ASTM A240 316 Stainless Steel gate fully machined and surface ground to provide a smooth sealing surface for the seals. All edges are chamfered to extend packing life and provide a superior packing seal.
- Heavy Duty Cast CF8 304 Stainless Steel Yoke, Stemnut Retainer and Stem Clevis.
- 14" and larger valves are provided with a ball bearing yoke bushing to reduce handwheel rimpull.
- Braided Teflon Synthetic Packing is Standard 3-11 Ph Rating.
- Cast WCB Steel Handwheel (weldable).
- Easily adapted to Pneumatic Cylinder, Hydraulic Cylinder, Spring Cylinder, 3:1 and 4:1 Bevel Gear, Lever And Electric Motor Operator (no welding required).

Note: not for deadend service unless a ring or blind flange is used

### Options

- Alloys - 317L, Duplex 2205, 2507, 904L, Other - Contact Factory
- Polymer Seals - HDPE, UHMWPE, Polyurethane - Contact Factory
- Retaining Rings - Abrasion Resistant Hardened Stainless Steel
- Mechanical Lockouts - Manual And Actuated Valves
- OSHA Gate Guard
- Pneumatic, Hydraulic And Spring Cylinder, Electric Motor, 3:1 or 4:1 Manual Bevel Gear, Lever, Chainwheel, Stem Extension
- Packing - Ptfе, Graphite, Kevlar, Food Grade
- Purge / Flushing Ports
- Live Loaded Packing System
- Limit/proximity Switches, Solenoid Valves, Air Sets, Speed Controls, Exhaust Mufflers, Positioners, Air Tank Failsafe System, Air Booster
- V-port Or Engineered Shape Inserts For Flow Control
- Inlet Deflector Cone
- Ni-resist Alloy Stemnut
- Specialty Gate Coatings • Bonneted Design

### Previous Model FV-150-DP

Optional Operators see [www.knifegates.com](http://www.knifegates.com) for details



Cylinder



Bevel Gear



Electric Motor



Chain Wheel



Lever



**Fabricast Valve Company**  
 1061 Industrial Way, Longview, WA 98632  
**Toll-Free** 1-877-264-2503  
**Local** (360) 425-0306 **Fax** (360) 425-0353  
 www.knifegates.com  
 sales@fabricastvalve.com

# FIG 61

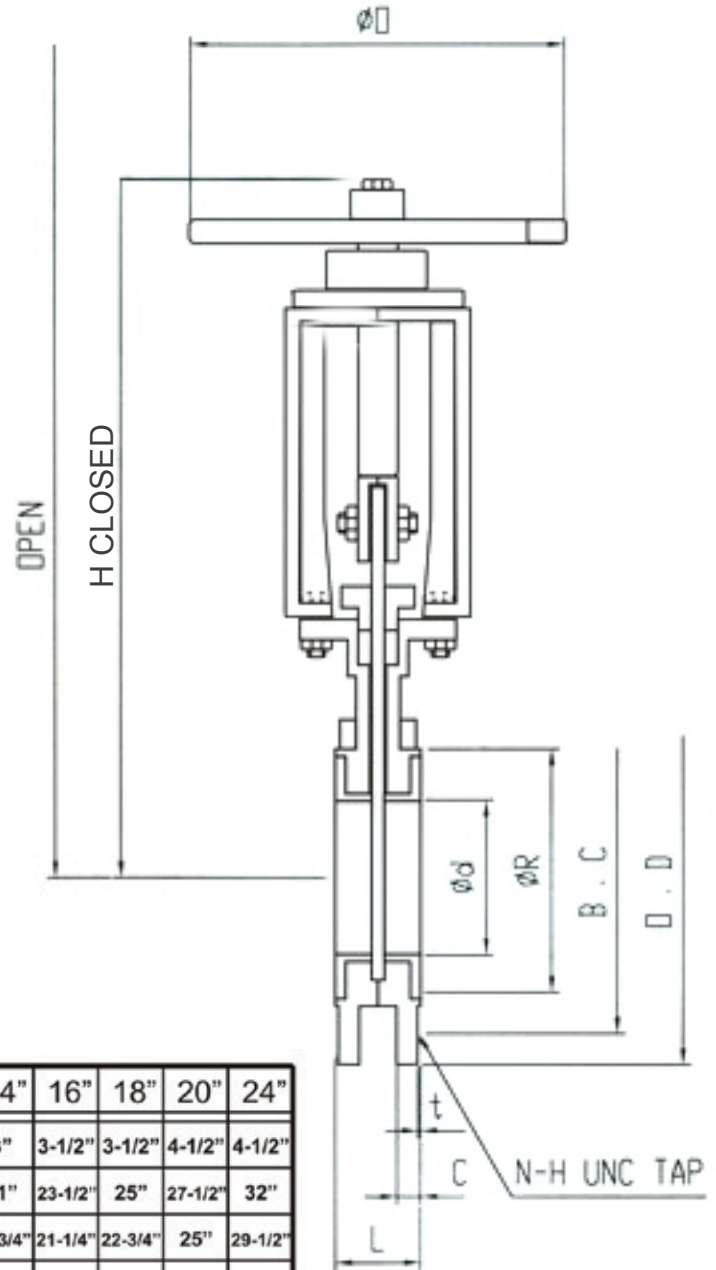
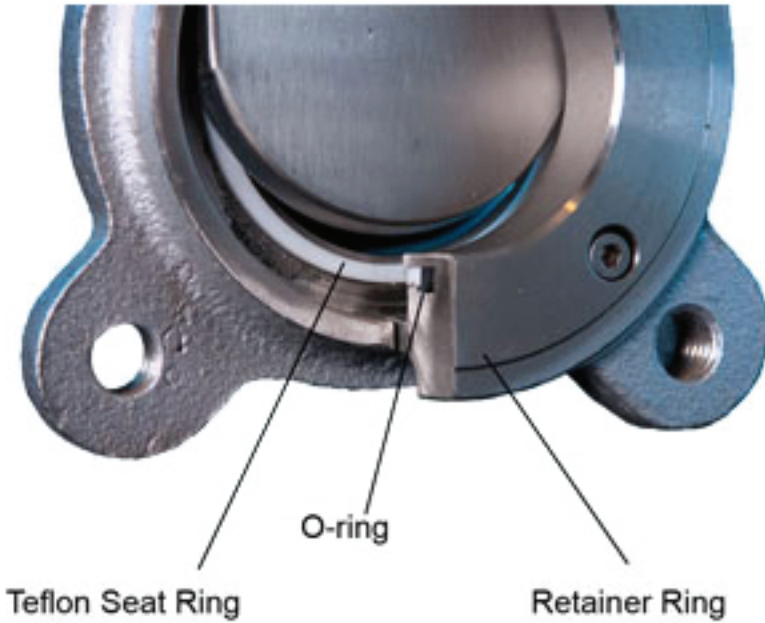

**61 - 4 CF8**  
**61 - 6 CF8M**  
**61 - 7 CG8M**

Size		2"	3"	4"	6"	8"	10"	12"	14"	16"	18"	20"	24"
Face to Face	<b>F-F</b>	1-7/8"	2"	2"	2-1/4"	2-3/4"	2-3/4"	3"	3"	3-1/2"	3-1/2"	4-1/2"	4-1/2"
Flange OD	<b>OD</b>	6"	7-1/2"	9"	11"	13-1/2"	16"	19"	21"	23-1/2"	25"	27-1/2"	32"
Bolt Circle	<b>BC</b>	4-3/4"	6"	7-1/2"	9-1/2"	11-3/4"	14-1/4"	17"	18-3/4"	21-1/4"	22-3/4"	25"	29-1/2"
Inside Diameter	<b>ID</b>	1-7/8"	2-7/8"	3-3/4"	5-3/4"	7-1/2"	9-1/2"	11-3/8"	13-1/4"	15-1/4"	17-1/4"	19-1/4"	23-1/4"
Number of Holes	<b>N</b>	4	4	8	8	8	12	12	12	16	16	20	20
Hole D&T Size	<b>D</b>	5/8"-11	5/8"-11	5/8"-11	3/4"-10	3/4"-10	7/8"-9	7/8"-9	1"-8	1"-8	1-1/8"-7	1-1/8"-7	1-1/4"-7
C'L to Top Closed	<b>H-Closed</b>	13-5/8"	16"	17-3/4"	21-5/8"	26-3/4"	32-1/8"	36-3/8"	42"	46-3/4"	52-3/8"	56"	62-7/8"
C/L to Top Open	<b>H-OPEN</b>	16"	19-3/4"	21-5/8"	27-3/4"	34-3/4"	42-3/4"	48-5/8"	55-1/4"	63-1/8"	70-1/2"	75-5/8"	85-5/8"
Handwheel Dia.	<b>H/W</b>	8"	8"	8"	12"	12"	15"	15"	15"	20"	20"	20"	30"
Raised Face Diameter	<b>RF</b>	3-5/8"	5"	6-3/16"	8-1/2"	10-5/8"	12-3/4"	15"	16-1/4"	18-1/2"	21"	23"	27-1/4"
Weight (lbs.)		20	29	38	52	85	120	160	212	300	350	480	600



**Fabricast Valve Company**  
1061 Industrial Way, Longview, WA 98632  
**Toll-Free** 1-877-264-2503  
**Local** (360) 425-0306 **Fax** (360) 425-0353  
www.knifegates.com  
sales@fabricastvalve.com

## Fabricast Valve

### FIGURE 61-DP PTFE SEATED KNIFE GATE VALVE

The Fabricast Valve FIG. 61-DP is a PTFE seated Knife gate valve featuring a cast stainless steel body, packing gland, gate, and yoke.

The heavy-duty cast body resists deflection from line loads and internal pressure. It is tested to withstand up to 150 PSI of pressure as required by MSS SP-81 and ASME B16.5 Class 150 specifications.

We offer seating options such as an o-ring resilient insert, or hard-face surfacing to prevent galling from high cycle, high end pressure, and abrasive applications. Also standard is a precision machined stainless steel gate designed to withstand pressures up to 150 PSI.

It's beveled design provides shut-off capability in thick media such as pulp stock, slurries, and solids such as pellets or powders. The stainless steel stem resists corrosion, and is accompanied by a stainless steel stem nut retainer that protects the brass stem bushing from harsh environments, and reduces operating torque.

Our Teflon Synthetic Packing is rated standard with a Ph range of 3-11, and temperature rating up to 500. Converting the heavy-duty yoke from the handwheel operator to cylinder, bevel gear, or electric motor is easy and requires no welding.

Available in T304, T316, T317 Stainless Steel.

Flanges match ANSI 150LB, PN10, TABLE "D", JIS 10 Standard with all tapped holes.

PREVIOUS MODEL NAME WAS FV 150-DP.

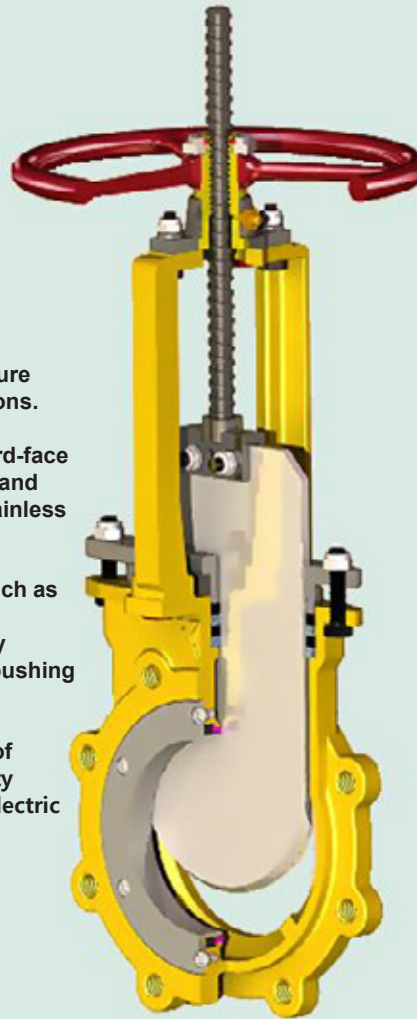

#### Optional Operators



Cylinder



Lever

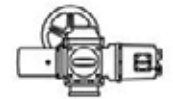

Electric

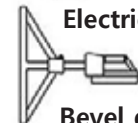

Bevel gear



Chain Wheel



**Fabricast Valve Company**  
 1061 Industrial Way, Longview, WA 98632  
**Toll-Free 1-877-264-2503**  
**Local (360) 425-0306 Fax (360) 425-0353**  
 www.knifegates.com  
 sales@fabricastvalve.com

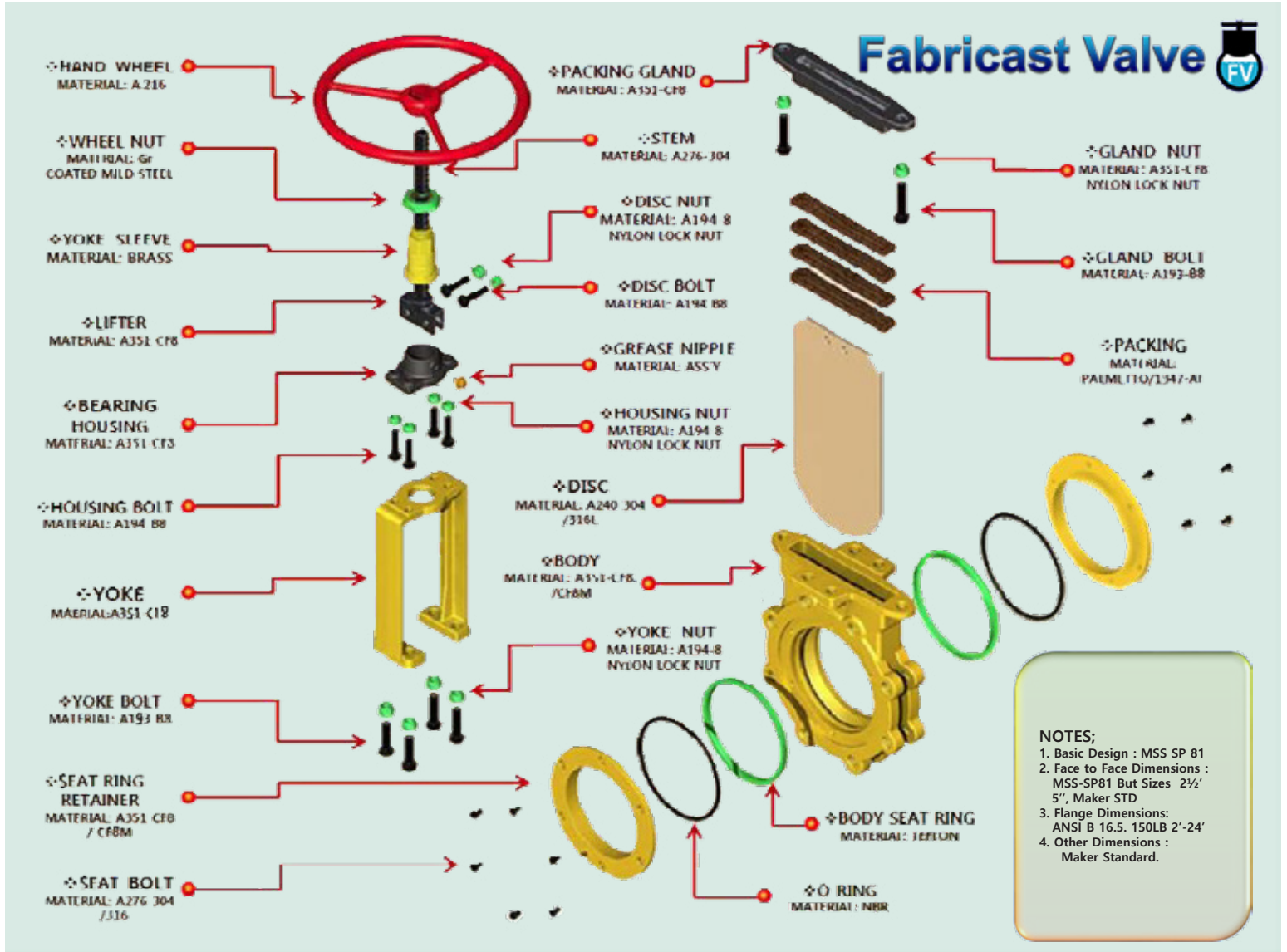



**Fabricast Valve Company**  
 1061 Industrial Way, Longview, WA 98632  
**Toll-Free 1-877-264-2503**  
**Local (360) 425-0306 Fax (360) 425-0353**  
 www.knifegates.com  
 sales@fabricastvalve.com

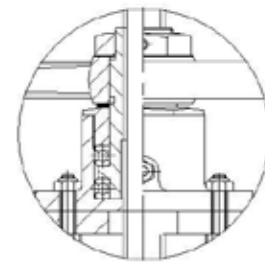
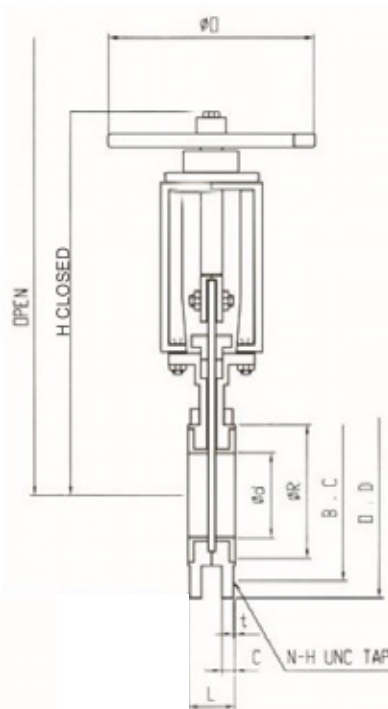
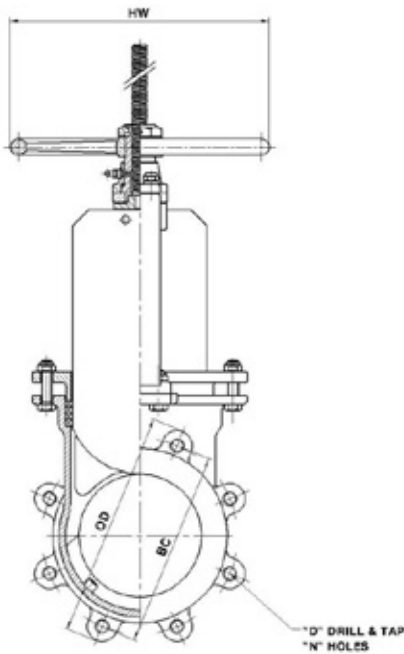

For sizes 14" and larger

Size		2"	3"	4"	6"	8"	10"	12"	14"	16"	18"	20"	24"
Face to Face	<b>F-F</b>	1-7/8"	2"	2"	2-1/4"	2-3/4"	2-3/4"	3"	3"	3-1/2"	3-1/2"	4-1/2"	4-1/2"
Flange OD	<b>OD</b>	6"	7-1/2"	9"	11"	13-1/2"	16"	19"	21"	23-1/2"	25"	27-1/2"	32"
Bolt Circle	<b>BC</b>	4-3/4"	6"	7-1/2"	9-1/2"	11-3/4"	14-1/4"	17"	18-3/4"	21-1/4"	22-3/4"	25"	29-1/2"
Inside Diameter	<b>ID</b>	1-7/8"	2-7/8"	3-3/4"	5-3/4"	7-1/2"	9-1/2"	11-3/8"					
Number of Holes	<b>N</b>	4	4	8	8	8	12	12	12	16	16	20	20
Hole D&T Size	<b>D</b>	5/8"-11	5/8"-11	5/8"-11	3/4"-10	3/4"-10	7/8"-9	7/8"-9	1"-8	1"-8	1-1/8"-7	1-1/8"-7	1-1/4"-7
C/L to Top Closed	<b>H-Closed</b>	13-5/8"	16"	17-3/4"	21-5/8"	26-3/4"	32-1/8"	36-3/8"	42"	46-3/4"	52-3/8"	56"	62-7/8"
C/L to Top Open	<b>H-OPEN</b>	16"	19-3/4"	21-5/8"	27-3/4"	34-3/4"	42-3/4"	48-5/8"	55-1/4"	63-1/8"	70-1/2"	75-5/8"	85-5/8"
Handwheel Dia.	<b>H/W</b>	8"	8"	8"	12"	12"	15"	15"	15"	20"	20"	20"	30"
Raised Face Diameter	<b>RF</b>	3-5/8"	5"	6-3/16"	8-1/2"	10-5/8"	12-3/4"	15"	16-1/4"	18-1/2"	21"	23"	27-1/4"
Weight (lbs.)		20	29	38	52	85	120	160	212	300	350	480	600



**Fabricast Valve Company**  
 1061 Industrial Way, Longview, WA 98632  
 Toll-Free 1-877-264-2503  
 Local (360) 425-0306 Fax (360) 425-0353  
 www.knifegates.com  
 sales@fabricastvalve.com

# FIG 215

FIG 215

Fabricast Valve



The Fabricast FIG 215 is a metal seated, uni-directional o-port slide gate valve. Designed and tested to MSS SP81 and ASME B16.5 specifications. For use in heavy solids flow media – hd stock, powders, hopper bottoms or anywhere a cutting action is required to close the valve.

### Features

- Heavy duty fabricated and welded carbon- stainless steel body 2" - 72", packing gland, yoke, stemnut retainer and gate clevis.
- Full Port.
- 150 PSI CWP rated.
- Precision CNC machined valve body and stem
- ASTM a 240 304 stainless steel o-port gate fully machined and surface ground. All edges are chamfered to extend packing life and to provide a superior atmospheric seal.
- 14" and larger valves are supplied with a ball bearing yoke bushing to reduce handwheel rimpull
- Braided teflon synthetic packing is standard. 3-11 PH rating.
- Cast WCB steel handwheel (weldable).
- Easily adapted to air cylinder, hydraulic cylinder, bevel gear, lever or electric motor operator (no welding required).

### Options

- O-Ring seat - BUNA N 200 deg. F. EPDM 300 deg. F. HDPE / UHMWPE 200 deg. f. FKM/VITON - 400 deg F. Other - contact factory.
- Other Alloys - CS, 304, 310, 316, 317L, Duplex 2205, 2507, 904L, Hastelloy, titanium other - contact factory.
- Mechanical lockouts - manual and actuated valves
- OSHA gate guard
- Pneumatic, hydraulic and spring cylinder, electric motor operator, • 3:1 and 4:1 bevel gear operator, chainwheel, stem extensions, lever operator
- Packings - ptfе, graphite, kevlar, food grade, other - contact vfactory
- Purge / flushing ports
- Limit / proximity switches, solenoid valves, positioners, air sets, speed controls, exhaust mufflers, air tank failsafe systems, air boosters
- V port for more precise flow control
- Deflector cones for abrasive service
- Ni-resist alloy stemnut
- Live loaded packing system
- Specialty gate coatings
- Hardsurfacing for abrasive service
- Backing ring for reverse flow or horizontal valve orientation
- Bonneted design
- High pressure • High temperature



Made in USA

**Previous Model**  
**FV-150-SG**

Optional Operators see [www.knifegates.com](http://www.knifegates.com) for details



Cylinder



Bevel Gear



Electric Motor



Chain Wheel



Lever





**Fabricast Valve Company**  
 1061 Industrial Way, Longview, WA 98632  
 Toll-Free 1-877-264-2503  
 Local (360) 425-0306 Fax (360) 425-0353  
 www.knifegates.com  
 sales@fabricastvalve.com

# FIG 215

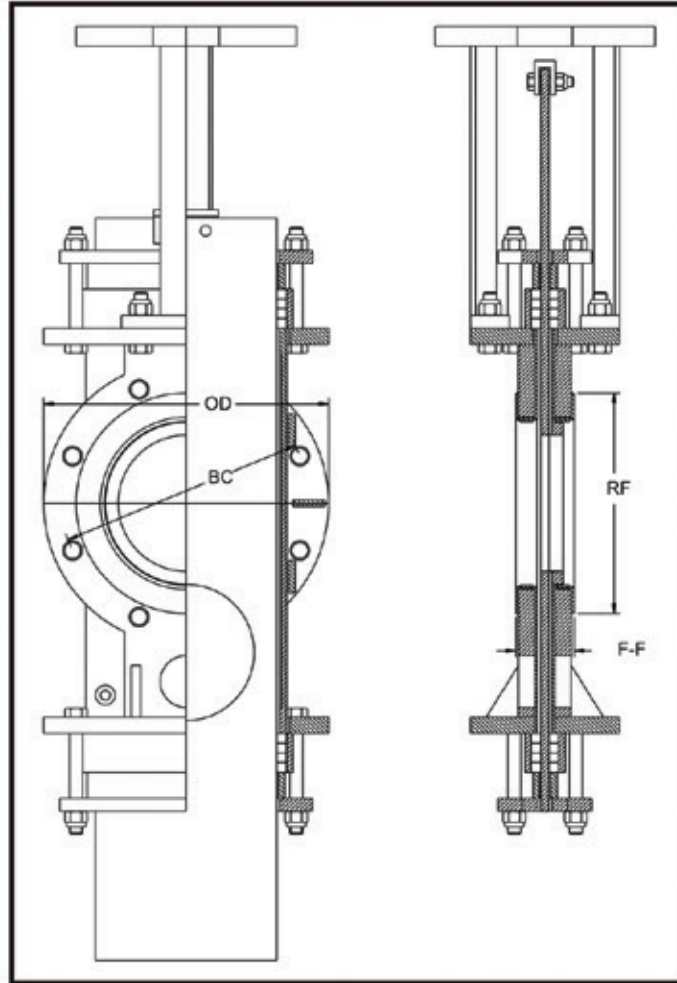

Size	2"	3"	4"	6"	8"	10"	12"	14"	16"	18"	20"	24"
Face to Face <b>F-F</b>	1-7/8"	2"	2"	2-1/4"	2-3/4"	2-3/4"	3"	3"	3-1/2"	3-1/2"	4-1/2"	4-1/2"
Flange OD <b>OD</b>	6"	7-1/2"	9"	11"	13-1/2"	16"	19"	21"	23-1/2"	25"	27-1/2"	32"
Bolt Circle <b>BC</b>	4-3/4"	6"	7-1/2"	9-1/2"	11-3/4"	14-1/4"	17"	18-3/4"	21-1/4"	22-3/4"	25"	29-1/2"
Inside Diameter <b>ID</b>	2"	3"	4"	6"	8"	10"	12"	13-5/8"	15-1/2"	17-1/2"	19-1/2"	23-3/8"
Number of Holes <b>N</b>	4	4	8	8	8	12	12	12	16	16	20	20
Hole D&T Size <b>D</b>	5/8"-11	5/8"-11	5/8"-11	3/4"-10	3/4"-10	7/8"-9	7/8"-9	1"-8	1"-8	1-1/8"-7	1-1/8"-7	1-1/4"-7
OA Length	30"	33"	38"	51"	62"	74"	85"	91"	102"	112"	122"	148"
C/L to Top Open <b>H-OPEN</b>	18	21	24	31	37	44	50	53	58	63	68	80
Handwheel Dia. <b>H/W</b>	8"	8"	8"	12"	12"	15"	15"	15"	20"	20"	20"	30"
Raised Face Diameter <b>RF</b>	3-5/8"	5"	6-3/16"	8-1/2"	10-5/8"	12-3/4"	15"	16-1/4"	18-1/2"	21"	23"	27-1/4"
Weight (lbs.)	77	77	90	119	162	238	325	442	558	640	910	1200

**Fabricast Valve**  
 Knife Gate Valves & Custom Fabrication / phone (360) 425-0306, fax (360) 425-0353



**Fabricast Valve Company**  
 1061 Industrial Way, Longview, WA 98632  
**Toll-Free 1-877-264-2503**  
**Local (360) 425-0306 Fax (360) 425-0353**  
 www.knifegates.com  
 sales@fabricastvalve.com

# FIG 240

FIG 240

Fabricast Valve

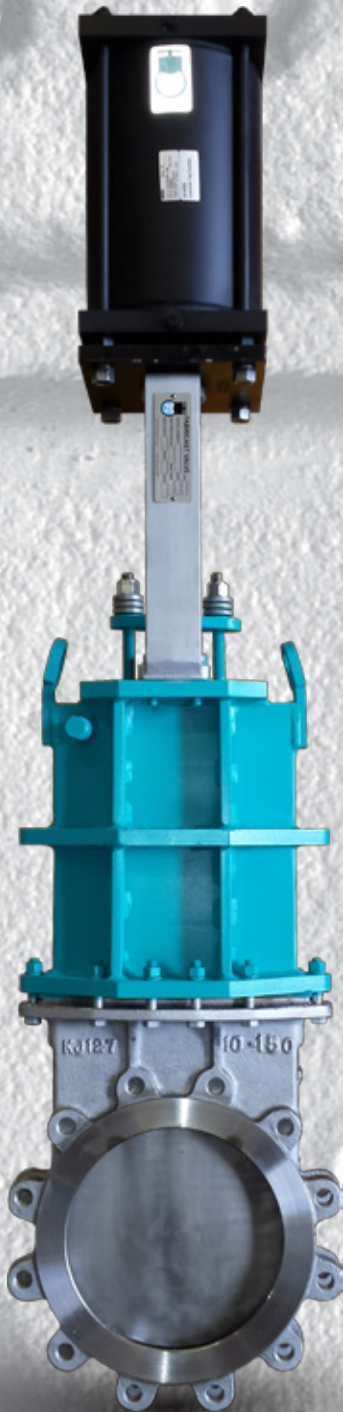

The Fabricast FIG 240 is a bolted bonnet, high performance knife gate valve. Designed and tested to MSS SP81 and ASME B16.5 specifications.

### Features

- Heavy Duty Cast CF8 304 or CF8M 316 Stainless Steel Body, in sizes 2" - 36", 42" and larger valves are fully fabricated from either plate steel, stainless steel or higher alloy.
- 150 PSI CWP Rated.
- Fully fabricated pressurized bolted bonnet.
- Standard seating is uni-directional metal to metal seat. Seating options include uni-directional metal seat with elastomer o-ring, dual replaceable polymer seat (DP) style body and rings.
- ASTM A 240 304 or 316 Stainless Steel gate fully machined, and surface ground.
- 14" and larger valves are supplied with a ball bearing yoke bushing to reduce handwheel rimpull.
- Braided Teflon Synthetic Packing is standard 3-11 PH rating.
- Cast WCB Steel handwheel (weldable)
- Easily adapted to Air Cylinder, Hydraulic Cylinder, Bevel Gear, Lever or Electric Motor Operator (no welding required).

### Options

- O-ring Seat - Buna N 200 Deg F, EPDM 300 Deg F, HDPE/UHMWPE 200 Deg F, FKM/Viton - 400 Deg F. Other - Contact Factory
- Other Alloys - 310, 316, 317L, Duplex 2205, 2507, 904L, Hastelloy, Titanium Other - Contact Factory
- Mechanical Lockouts - Manual And Actuated Valves
- Osha Gate Guard
- Pneumatic, Hydraulic And Spring Cylinder, Electric Motor Operator, 3:1 And 4:1 Bevel Gear Operator, Chainwheel, Stem Extensions, Lever Operator
- Packings-PTFE, Graphite, Kevlar, Food Grade, Other-Contact Factory
- Purge / Flushing Ports
- Limit/Proximity Switches, Solenoid Valves, Positioners, Air Sets, Speed Controls, Exhaust Mufflers, Air Tank Failsafe Systems, Air Boosters
- V Port Inserts For Flow Control
- Deflector Cones For Abrasive Service
- Ni-resist Alloy Stemnut
- Live Loaded Packing System
- Specialty Gate Coatings
- Hard surfacing For Abrasive Service
- Backing Ring For Reverse Flow Or Horizontal Valve Orientation
- Lantern Packing Gland
- High Pressure
- High Temperature



**Previous Model**  
**FV-150-BB**

Optional Operators see [www.knifegates.com](http://www.knifegates.com) for details



Cylinder



Bevel Gear



Electric Motor



Chain Wheel



Lever



**Fabricast Valve Company**  
 1061 Industrial Way, Longview, WA 98632  
 Toll-Free 1-877-264-2503  
 Local (360) 425-0306 Fax (360) 425-0353  
 www.knifegates.com  
 sales@fabricastvalve.com

# FIG 240



Available:  
 Contact Factory

Size	2"	3"	4"	6"	8"	10"	12"	14"	16"	18"	20"	24"	30"	36"
Face to Face <b>F-F</b>	1-7/8"	2"	2"	2-1/4"	2-3/4"	2-3/4"	3"	3"	3-1/2"	3-1/2"	4-1/2"	4-1/2"		
Flange OD <b>OD</b>	6"	7-1/2"	9"	11"	13-1/2"	16"	19"	21"	23-1/2"	25"	27-1/2"	32"		
Bolt Circle <b>BC</b>	4-3/4"	6"	7-1/2"	9-1/2"	11-3/4"	14-1/4"	17"	18-3/4"	21-1/4"	22-3/4"	25"	29-1/2"		
Inside Diameter <b>ID</b>	2"	3"	4"	6"	8"	10"	12"	13-5/8"	15-1/2"	17-1/2"	19-1/2"	23-3/8"		
Number of Holes <b>N</b>	4	4	8	8	8	12	12	12	16	16	20	20		
Hole D&T Size <b>D</b>	5/8"-11	5/8"-11	5/8"-11	3/4"-10	3/4"-10	7/8"-9	7/8"-9	1"-8	1"-8	1-1/8"-7	1-1/8"-7	1-1/4"-7		
C/L to Top Closed <b>H-CLOSED</b>	21-1/2"	21-1/2"	24-1/4"	30"	36-1/4"	41-1/2"	48"	58"	64"	70"	74-1/4"	87-1/2"		
C/L to Top Open <b>H-OPEN</b>	24"	24"	28"	30"	44"	51"	60"	71-1/2"	80"	88"	93-1/2"	111"		
Handwheel Dia. <b>H/W</b>	8"	8"	8"	12"	12"	15"	15"	15"	20"	20"	20"	30"		
Raised Face Diameter <b>RF</b>	3-5/8"	5"	6-3/16"	8-1/2"	10-5/8"	12-3/4"	15"	16-1/4"	18-1/2"	21"	23"	27-1/4"		
Weight (lbs.)	73	79	87	116	204	269	368	451	592	674	823	1163		

**Fabricast Valve**  
 Knife Gate Valves & Custom Fabrication / phone (360) 425-0306, fax (360) 425-0353



**Fabricast Valve Company**  
1061 Industrial Way, Longview, WA 98632  
**Toll-Free** 1-877-264-2503  
**Local** (360) 425-0306 **Fax** (360) 425-0353  
www.knifegates.com  
sales@fabricastvalve.com

The Fabricast FIG 6 is a fabricated and welded tilting / angle disc check valve. Designed and tested to MSS SP61 and ASME B16.5 specifications.

### Features

- Heavy duty fabricated 304 or 316 Stainless Steel body and gate disc. Standard size range is 2"- 48"
- 150 Psi Cwp Rated
- Drip Tight Reverse Flow Seating To MSS SP61
- Precision CNC Machined Valve Body And Gate Disc

Note – For Both Horizontal Or Vertical Mounting Orientations

### Options

Other Alloys – 317L, Duplex 2205, 2507, 904L



FIG 6

Fabricast Valve

**Previous Model**  
**FV-150-TDCV**





**Fabricast Valve Company**  
 1061 Industrial Way, Longview, WA 98632  
**Toll-Free** 1-877-264-2503  
**Local** (360) 425-0306 **Fax** (360) 425-0353  
 www.knifegates.com  
 sales@fabricastvalve.com

# FIG 6

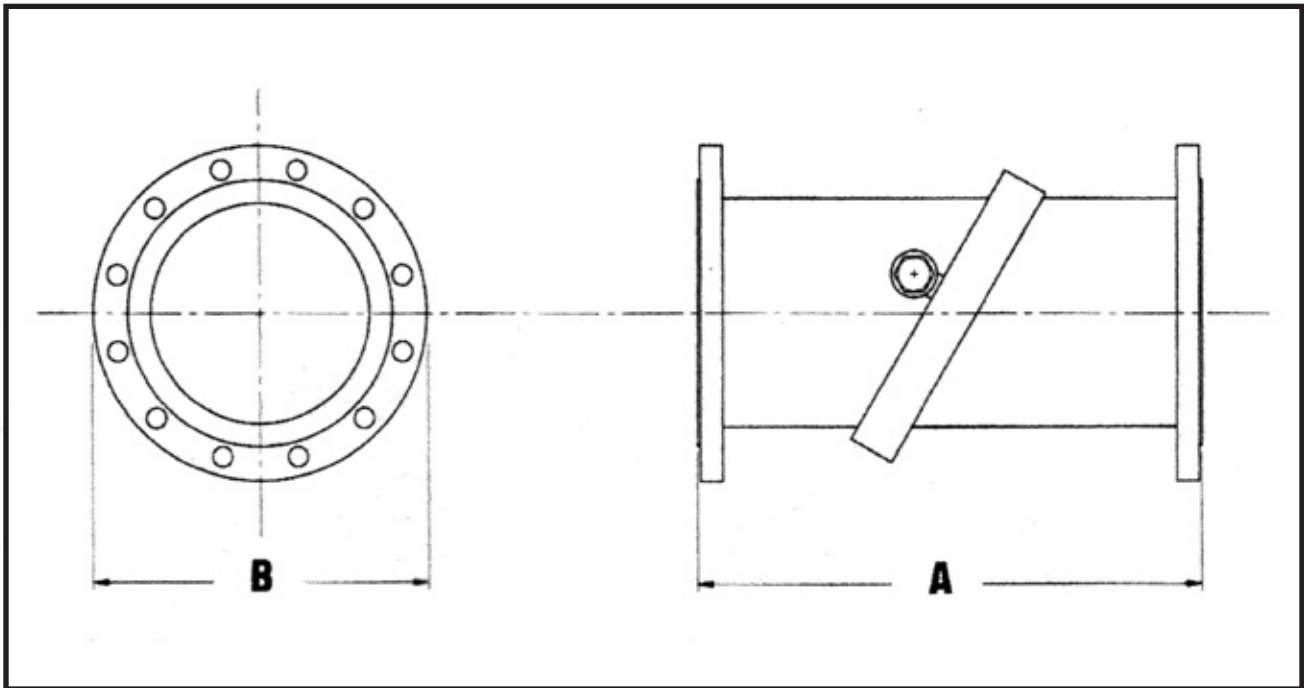

SIZE	3	4	6	8	10	12	14	16	18	20	24
F-F	9.5	11.5	14	18	21.75	25.5	28	29.5	31	32.5	39.5
MIN	4.75	5.38	7.5	8.63	10.25	11.63	12.88	13.88	15.25	16.88	20
FLG	7.5	9	11	13.5	16	19	21	23.5	25	27.5	32
WT	20	30	54	85	110	182	195	258	345	470	735



**Fabricast Valve Company**  
 1061 Industrial Way, Longview, WA 98632  
**Toll-Free** 1-877-264-2503  
**Local** (360) 425-0306 **Fax** (360) 425-0353  
 www.knifegates.com  
 sales@fabricastvalve.com

# FIG 145

FIG 145

Fabricast Valve



The Fabricast FIG 145 is a unique high performance polymer lined bi-directional drip tight knife gate valve. Designed and tested to mss sp81 and asme b16.5 specifications.

#### Features

- Heavy duty fabricated ASTM A36 Carbon Steel body, packing gland and yoke. Standard size range is 2"- 48"
- 3 piece replaceable polymer liners. Uhmwpe (ultra high molecular weight polyethylene) is standard rated to 180 deg f. The seat insert is a T shape that mechanically locks it into the liners. The liners and seat insert are sealed to the valve body with a special silicone sealant preventing the flow media coming in contact with the valve body. The full length body liners support the gate throughout the full stroke preventing deflection and premature packing wear. The packing chamber in the valve body is extra deep utilizing several rows of braided packing resulting in a superior atmospheric seal.
- 304 stainless steel fixed retaining rings are standard
- Full port
- 150 psi cwp rated – see FV 300 – LKG for higher pressure
- Precision cnc machined valve body and stem
- \* ASTM a 240 304 stainless steel gate fully machined and surface ground. All edges are chamfered to extend packing life and to provide a superior atmospheric seal.
- 14" and larger valves are supplied with a ball bearing yoke bushing to reduce handwheel rimpull
- Braided teflon synthetic packing is standard 3-11 ph rating
- Locking fasteners are standard on all fabricast valves
- Cast WCB steel handwheel (weldable)
- Easily adapted to air cylinder, hydraulic cylinder, bevel gear, lever or electric motor operator (no welding required)

#### Options

- Liners/insert - Polyurethane 180 Deg F, Polypropylene 225 Deg F, High temp UHMWPE 280 Deg F, Teflon 400 Deg F, Other - contact factory.
- Other alloys - 304, 316, 317l, duplex 2205, 2507,904l, Hastelloy, Titanium Other - contact factory
- Mechanical lockouts - manual and actuated valves
- OSHA gate guard
- Pneumatic, hydraulic and spring cylinder, electric motor operator, 3:1 and 4:1 bevel gear operator, chainwheel, stem extensions, lever operator
- Packing - PTFE, graphite, kevlar, food grade, other - contact factory
- Purge / flushing ports
- Limit / proximity switches, solenoid valves, positioners, air sets, speed controls, exhaust mufflers, air tank failsafe systems, air boosters
- V port insert for flow control
- Deflector cones for abrasive service
- Replaceable abrasion resistant and hardened retaining rings
- Seat cavity filler
- Specialty exterior coatings
- Bonneted design
- Slide gate design - FIG 202
- Ni-resist alloy stemnut
- Live loaded packing system
- Specialty gate coatings
- Hardsurfacing for abrasive service



Made in USA

**Previous Model**  
**FV-150-LKG**

Optional Operators see [www.knifegates.com](http://www.knifegates.com) for details



Cylinder



Bevel Gear



Electric Motor



Chain Wheel



Lever



**Fabricast Valve Company**  
 1061 Industrial Way, Longview, WA 98632  
**Toll-Free** 1-877-264-2503  
**Local** (360) 425-0306 **Fax** (360) 425-0353  
 www.knifegates.com  
 sales@fabricastvalve.com

# FIG 145

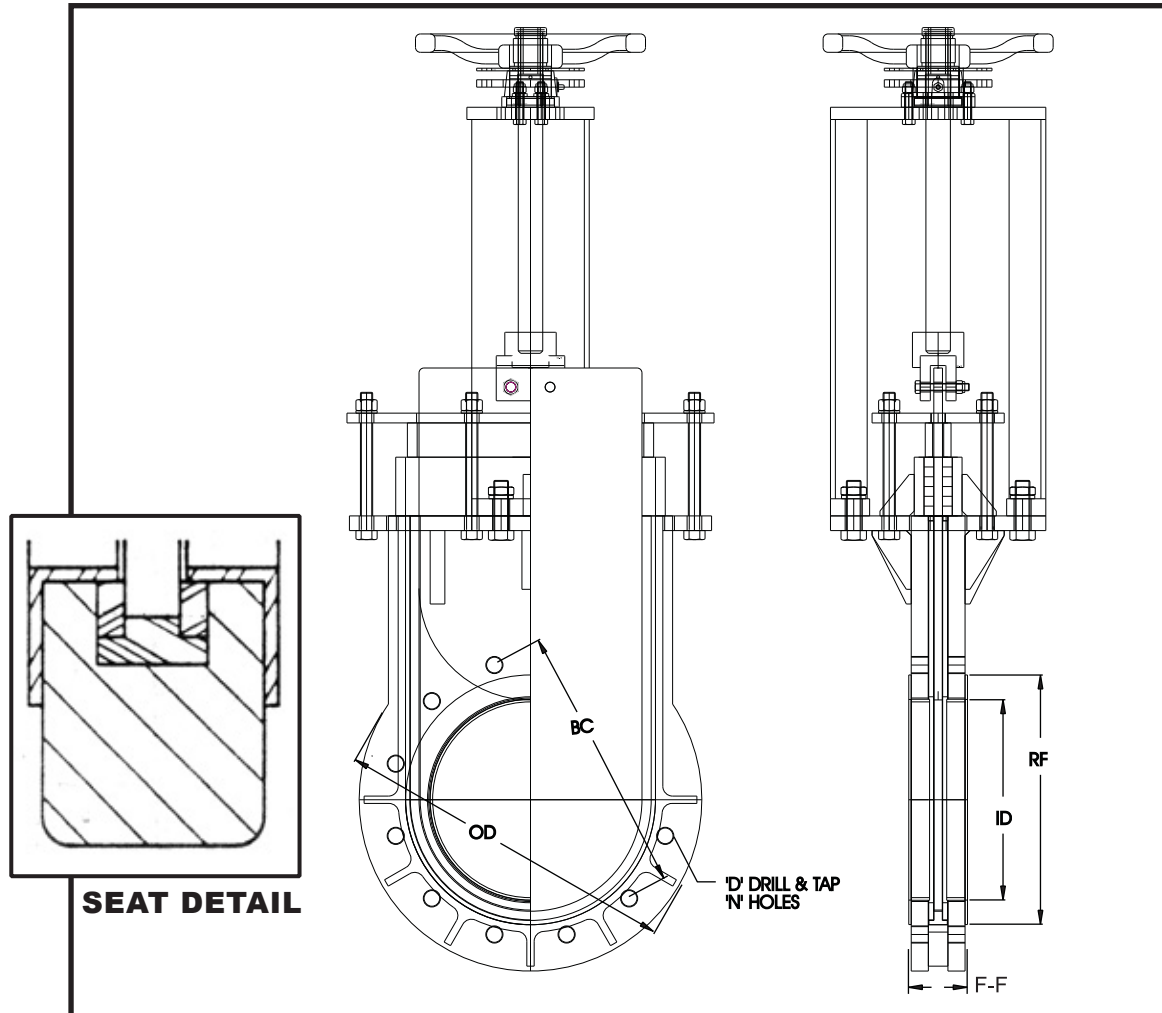

Size		2"	3"	4"	6"	8"	10"	12"	14"	16"	18"	20"	24"
Face to Face	<b>F-F</b>	1-7/8"	2"	2"	2-1/4"	2-3/4"	2-3/4"	3"	3"	3-1/2"	3-1/2"	4-1/2"	4-1/2"
Flange OD	<b>OD</b>	6"	7-1/2"	9"	11"	13-1/2"	16"	19"	21"	23-1/2"	25"	27-1/2"	32"
Bolt Circle	<b>BC</b>	4-3/4"	6"	7-1/2"	9-1/2"	11-3/4"	14-1/4"	17"	18-3/4"	21-1/4"	22-3/4"	25"	29-1/2"
Inside Diameter	<b>ID</b>	2"	3"	4"	6"	8"	10"	12"	14"	16"	18"	20"	24"
Number of Holes	<b>N</b>	4	4	8	8	8	12	12	12	16	16	20	20
Hole D&T Size	<b>D</b>	5/8"-11	5/8"-11	5/8"-11	3/4"-10	3/4"-10	7/8"-9	7/8"-9	1"-8	1"-8	1-1/8"-7	1-1/8"-7	1-1/4"-7
C/L to Top Closed	<b>H-CLOSED</b>	20-1/8"	20-1/8"	21-7/8"	28-1/8"	32-1/8"	34-1/2"	41-5/8"	45-1/2"	51"	57-1/4"	61"	69-3/4"
C/L to Top Open	<b>H-OPEN</b>	23"	23"	26"	33-7/8"	40"	45-1/4"	53-3/8"	59"	66-7/8"	74-5/8"	80-1/4"	93-3/8"
Handwheel Dia.	<b>H/W</b>	8"	8"	8"	12"	12"	15"	15"	15"	20"	20"	20"	30"
Raised Face Diameter	<b>RF</b>	3-5/8"	5"	6-3/16"	8-1/2"	10-5/8"	12-3/4"	15"	16-1/4"	18-1/2"	21"	23"	27-1/4"
Weight (lbs.)		55	55	70	105	157	218	330	435	560	685	950	1200



**Fabricast Valve Company**  
 1061 Industrial Way, Longview, WA 98632  
**Toll-Free 1-877-264-2503**  
**Local (360) 425-0306 Fax (360) 425-0353**  
 www.knifegates.com  
 sales@fabricastvalve.com

# FIG 345

FIG 345

Fabricast Valve



The Fabricast FIG 345 is a unique high performance polymer lined bi-directional drip tight knife gate valve. Designed and tested to MSS SP81 and ASME B16.5 specifications.

### Features

- Heavy duty fabricated ASTM A36 Carbon Steel Body, Packing Gland and Yoke. Standard size range is 2"- 48"
- 3 piece replaceable Polymer liners. UHMWPE (Ultra High Molecular Weight Polyethylene) is standard rated to 180 Deg F. The seat insert is a T-shape that mechanically locks it into the liners. The liners and seat insert are sealed to the valve body with a special silicone sealant preventing the flow media from coming in contact with the valve body. The full length body liners support the gate throughout the full stroke preventing deflection and premature packing wear. The packing chamber in the valve body is extra deep utilizing several rows of braided packing resulting in a superior atmospheric seal.
- 304 Stainless Steel Fixed Retaining Rings Are Standard
- Full Port
- 300 Psi Cwp Rated, Higher Pressures Avail - Contact Factory
- Precision Cnc Machined Valve Body and Stem
- ASTM A 240 304 Stainless Steel Gate Fully Machined and Surface Ground. All Edges Are Chamfered To Extend Packing Life and to provide a Superior Atmospheric Seal.
- 14" And Larger Valves Are Supplied With A Ball Bearing Yoke Bushing To Reduce Handwheel Rimpull
- Braided Teflon Synthetic Packing Is Standard 3-11 Ph Rating
- Locking Fasteners Are Standard On All Fabricast Valves
- Cast WCB Steel Handwheel (Weldable)
- Easily Adapted To Air Cylinder, Hydraulic Cylinder, Bevel Gear, Lever Or Electric Motor Operator (No Welding Required)

### Options

- Liners/insert - Polyurethane 180 Deg F, Polypropylene 225 Deg F, High Temperature UHMWPE 280 Deg F, Teflon 400 Deg F, Other - Contact Factory.
- Other Alloys - 304, 316, 317I, Duplex 2205, 2507, 904L, Hastelloy, Titanium, Other - Contact Factory
- Mechanical Lockouts - Manual and Actuated Valves
- OSHA Gate Guard
- Pneumatic, Hydraulic And Spring Cylinder, Electric Motor Operator, 3:1 and 4:1 Bevel Gear Operator, Chainwheel, Stem Extensions, Lever Operator
- Packing - PTFE, Graphite, Kevlar, Food Grade, Other - Contact Factory
- Purge / Flushing Ports
- Limit / Proximity Switches, Solenoid Valves, Positioners, Air Sets, Speed Controls, Exhaust
- Mufflers, Air Tank Failsafe Systems, Air Boosters
- V Port Insert For Flow Control
- Deflector Cones For Abrasive Service
- Replaceable Abrasion Resistant And Hardened Retaining Rings
- Seat Cavity Filler
- Specialty Exterior Coatings
- Bonneted Design
- Slide Gate Design - FIG 202
- Ni-resist Alloy Stemnut
- Live Loaded Packing System • Specialty Gate Coatings • Hardsurfacing for Abrasive Service • Ultra High Pressure Designs



**Made in USA**

**Previous Model**  
**FV-300-LKG**

Optional Operators see [www.knifegates.com](http://www.knifegates.com) for details



Cylinder



Bevel Gear



Electric Motor



Chain Wheel



Lever





**Fabricast Valve Company**  
 1061 Industrial Way, Longview, WA 98632  
**Toll-Free** 1-877-264-2503  
**Local** (360) 425-0306 **Fax** (360) 425-0353  
 www.knifegates.com  
 sales@fabricastvalve.com

# FIG 345

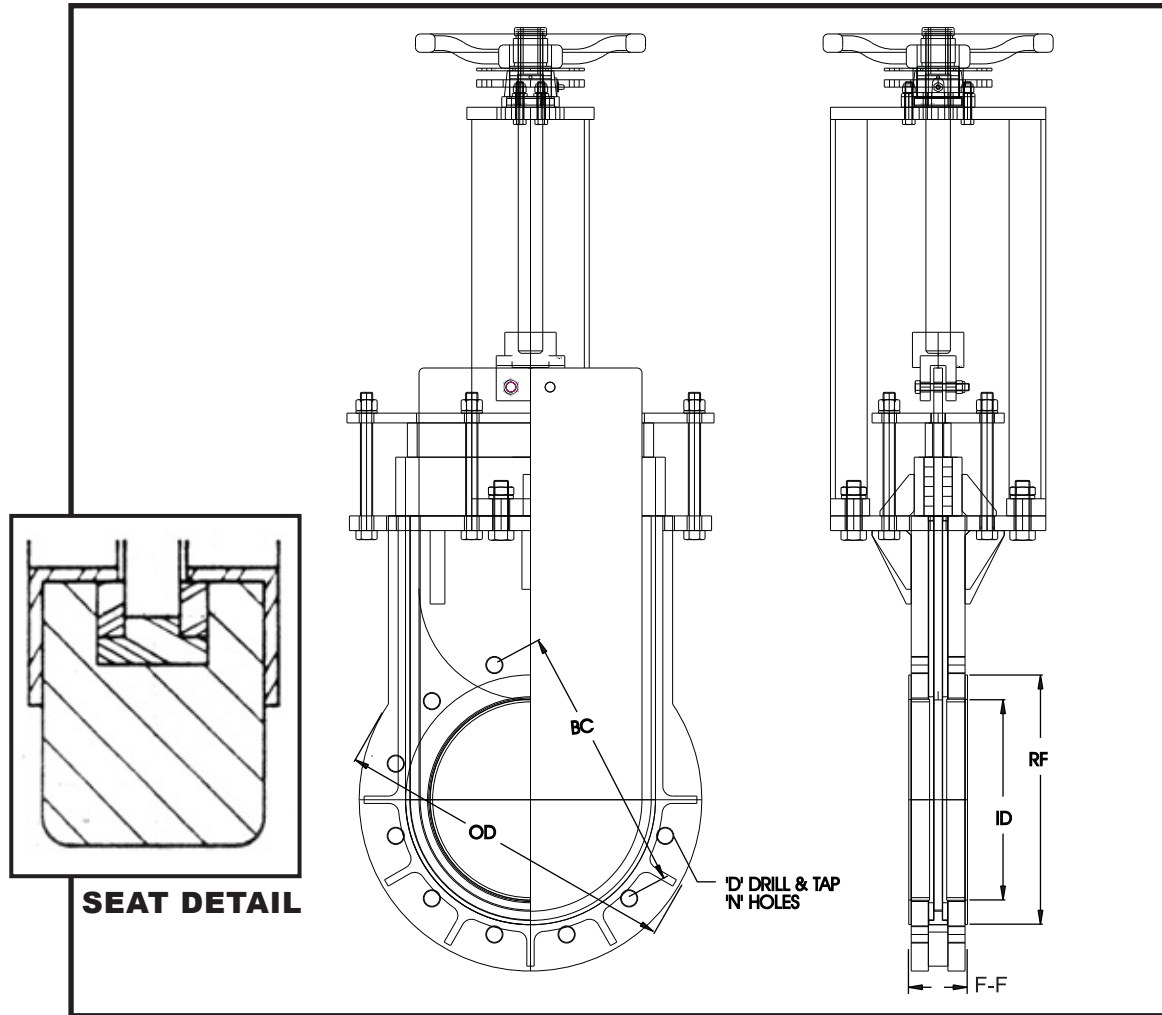

Size	2"	3"	4"	6"	8"	10"	12"	14"	16"	18"	20"	24"	
Custom Sizes	2-1/2"	5"	22"	26"	28"	32"	34"	38"	40"	44"			
Face to Face	<b>F-F</b>	2-1/4"	2-1/4"	2-1/4"	2-1/2"	3"	3"	3-1/4"	3-1/2"	3-3/4"	4"	5-1/4"	5-1/2"
Flange OD	<b>OD</b>	6-3/4"	8-1/2"	10-1/4"	12-3/4"	15-1/4"	17-3/4"	20-3/4"	23-1/4"	25-3/4"	28-1/4"	30-3/4"	36-1/4"
Bolt Circle	<b>BC</b>	6"	6-5/8"	7-7/8"	10-5/8"	13"	15-1/4"	17-3/4"	20-1/4"	22-1/2"	24-3/4"	27"	32"
Inside Diameter	<b>ID</b>	2"	3"	4"	6"	8"	10"	12"	14"	16"	18"	20"	24"
Number of Holes	<b>N</b>	8	8	8	12	12	16	16	20	20	24	24	24
Hole D&T Size	<b>D</b>	5/8"-11	3/4"-10	3/4"-10	3/4"-10	7/8"-9	1-8"	1-1/8"-7	1-1/8"-7	1-1/4"-7	1-1/4"-7	1-1/4"-7	1-1/2"-6
C/L to Top Closed	<b>H-CLOSED</b>	18-7/8"	21"	23-1/8"	29-5/8"	33-3/4"	38-3/4"	49-5/8"	54-1/8"	59"	65-1/4"	69-1/4"	78-1/8"
C/L to Top Open	<b>H-OPEN</b>	20-3/4"	24"	27-1/4"	41-7/8"	48-3/8"	45-1/4"	54"	61"	68"	76"	82"	95-1/2"
Handwheel Dia.	<b>H/W</b>	8"	8"	8"	12"	12"	15"	15"	15"	20"	20"	20"	30"
Raised Face Diameter	<b>RF</b>	3-5/8"	5"	6-3/16"	8-1/2"	10-5/8"	12-3/4"	15"	16-1/4"	18-1/2"	21"	23"	27-1/4"
Weight (lbs.)		71	82	93	134	201	267	453	557	739	893	1277	1685



**Fabricast Valve Company**  
 1061 Industrial Way, Longview, WA 98632  
**Toll-Free** 1-877-264-2503  
**Local** (360) 425-0306 **Fax** (360) 425-0353  
 www.knifegates.com  
 sales@fabricastvalve.com

# FIG 202

FIG 202

Fabricast Valve



*Shown with optional position transmitting hydraulic cylinder*

- Heavy duty fabricated ASTM A36 carbon steel body, packing gland and yoke. Standard size range is 2" - 24" - larger sizes available.
- 4 piece replaceable UHMW liners are standard rated to 180 degrees F. The side inserts are T shaped that mechanically locks them into the body liners. The liners and side inserts are sealed to the valve body with a special silicone sealant preventing the flow media from coming in contact with the valve body. The full length body liners support the gate throughout the full stroke preventing deflection and premature packing wear. Extra deep packing chamber with multiple rows of braided packing resulting in a superior atmospheric seal.
- ASTM A240 304 stainless steel retaining rings and precision surface ground gate are standard.
- Full port or specify to match a specific pipe ID.
- Standard 150 PSI CWP rated - higher pressure ratings available.
- No cavities to pack up with flow media and cause jamming.
- Does not discharge flow media to atmosphere.
- 304 stainless steel ACME threaded stem.
- Multiple rows of braided teflon synthetic packing is standard 3-11 PH range, 450 degrees F.
- Locking fasteners - standard on all Fabricast valves.
- Bevel gear operator - standard (3:1 or 4:1 depending on valve size).
- Easily adapted to air cylinder, hydraulic cylinder, electric motor (no welding required).

**OPTIONS:**

- Available body liners:
  - Polyurethane rated to 180 degree F.
  - Polypropylene rated to 225 degrees F.
  - Tivar UHMW rated to 280 degrees F.
  - Teflon rated to 400 degrees F.
- Alloy materials for body, gate and retaining rings: 316 stainless steel, Duplex stainless steels 2205, 2507, 904L, Hastelloy, Titanium or specify.
- OSHA upper and lower gate guards.
- Ring style lockout for manual bevel gear.
- Mechanical pin style open and closed lockouts for automated valves.
- Specialty packings PTFE, Graphite, Kevlar, FDA.
- Limit switches, proximity switches, solenoid valves, positioners, air sets, speed controls, exhaust mufflers, Linear positioning sensing cylinders, spring cylinders, failsafe system, air boosters
- Configured port for flow control and modulating applications.
- Inlet deflector cone.
- Replaceable abrasion resistant and hardened retaining rings.
- Replaceable polymer retaining rings.
- Bonneted design available.
- Live loaded packing system.
- Specialty gate and exterior coatings.
- Hardsurfacing - Stellite, Chrome carbide, Tungsten carbide for severe abrasive applications.



**Made in USA**

Optional Operators see [www.knifegates.com](http://www.knifegates.com) for details



Cylinder



Bevel Gear



Electric Motor



Chain Wheel



Lever



**Fabricast Valve Company**  
 1061 Industrial Way, Longview, WA 98632  
 Toll-Free 1-877-264-2503  
 Local (360) 425-0306 Fax (360) 425-0353  
 www.knifegates.com  
 sales@fabricastvalve.com

# FIG 202

## Slidegate Valve w/ Replaceable Polymer Liner [ 2" - 24" ]

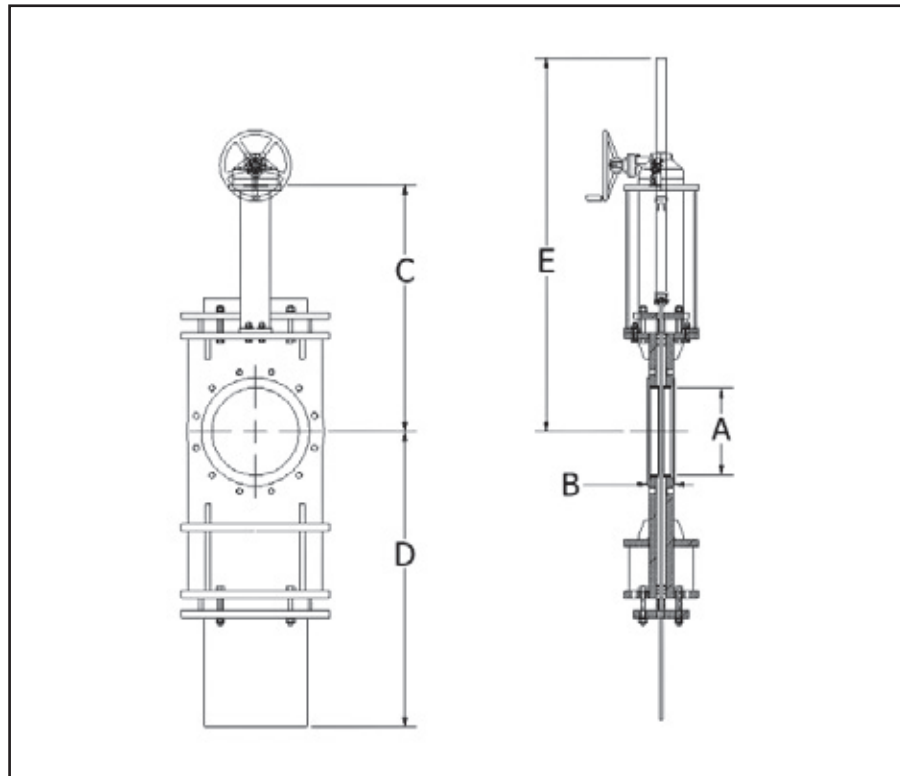

Valve Dimensions					
Valve Size	Port I.D. (A)	Face to Face (B)	Upper Length (C)	Lower Length (D)	Open Height (E)
2	2	2 1/2	15 1/2	13 1/2	22
3	3	2 1/2	17	15	22 1/2
4	4	2 1/2	19	18 1/2	27 1/2
6	6	2 3/4	22	23 1/2	32 1/2
8	8	3 1/4	25	28 1/2	37 1/2
10	10	3 1/4	29	34	43 1/2
12	12	3 1/2	32 1/2	39	49
14	13 1/4	3 1/2	36	43 1/2	53 3/4
16	15 1/4	3 3/4	39 1/2	48 1/2	59 3/4
18	17 1/4	3 3/4	42 1/2	54	64 3/4
20	19 1/4	4 1/2	46	59	70 1/4
24	23 1/4	4 1/2	52	69	80 1/4

*Note: All dimensions are in inches. Dimensions are a close approximation but will vary relative to customer's over-all specifications.*



**Fabricast Valve Company**  
 1061 Industrial Way, Longview, WA 98632  
**Toll-Free** 1-877-264-2503  
**Local** (360) 425-0306 **Fax** (360) 425-0353  
[www.knifegates.com](http://www.knifegates.com)  
[sales@fabricastvalve.com](mailto:sales@fabricastvalve.com)

# DBB FIG 145-UHMW DBB FIG 40-MM DBB FIG 50-PS

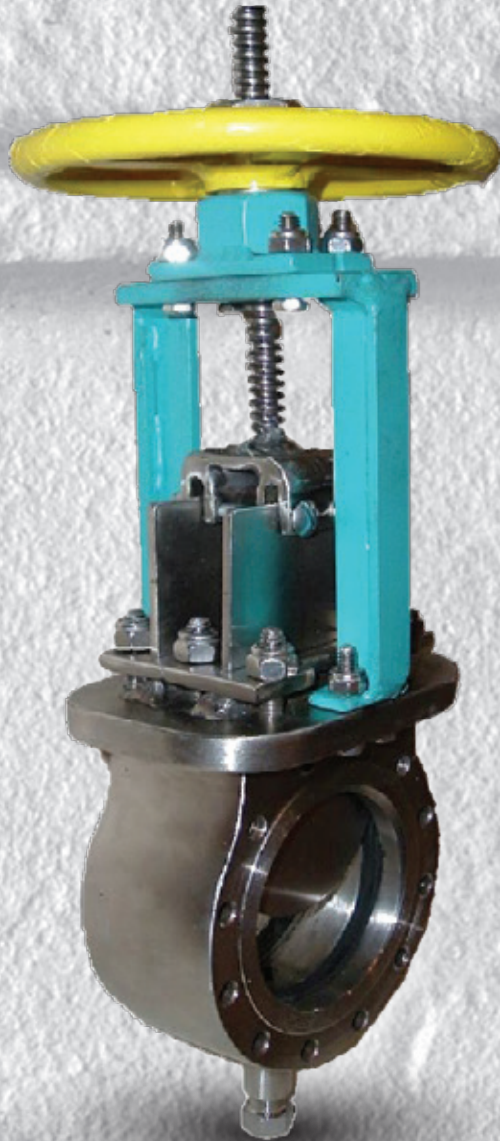

The Fabricast DBB FIG 145-UHMW, 40-MM, and 50-PS is a highly engineered, high performance, double gated polymer lined knife gate valve. Serves as both a double block and bleed valve and a line blind. Designed and tested to MSS SP61 and ASME B16.5 Specifications.

#### Features

- Heavy duty fabricated ASTM A36 Carbon Steel Body, Packing Gland and Yoke. Sizes up to 48"
- 6 piece replacement polymer liners. UHMWPE (ultra high molecular weight polyethylene is standard)
- The dual seat inserts are a "T" shape that mechanically locks them to the liners
- The liners and seat inserts are sealed to the valve body with a special silicone sealant preventing the flow media from coming in contact with the valve body
- The full length body liners support the gate throughout the full stroke, preventing deflection and premature packing wear
- The packing chamber in the valve body is extra deep, utilizing several rows of braided packing, resulting in a superior atmospheric seal
- In the bottom center of the body, between the dual gates, is a drain and plug
- 304 Stainless Steel fixed liner retaining rings are standard full port design, or can be made to match any pipeline I.D.
- 150 PSI CWP rated - higher pressure rating available
- ASTM A240 Dual 304 Stainless Steel gates fully machined and surface ground.
- All edges are chamfered to extend packing life and to provide a superior atmospheric seal.
- Manual valves are provided with a 4:1 ratio bevel gear operator
- Mechanical lockouts are standard - manual and actuated valves.
- Braided Teflon synthetic packing is standard 3-11 PH rating.
- Locking fasteners are standard on all Fabricast valves.
- Easily adapted to pneumatic and hydraulic cylinder or electric motor operator (no welding required)

#### Options

- Liners/insert - Polyurethane 180 Deg F, Polypropylene 225 Deg F, High Temperature UHMWPE 280 Deg F, Teflon 400 Deg F, Other - Contact Factory.
- Other Alloys - 316, 317L, Duplex 2205, 2507, 904L, Hastelloy, Titanium, Other - Contact Factory
- OSHA Gate Guard
- Pneumatic and Hydraulic Cylinder, Electric Motor Operator, Other-Contact Factory
- Packing - PTFE, Graphite, Kevlar, Food Grade, Other - Contact Factory
- Limit / Proximity Switches, Solenoid Valves, Positioners, Air Sets, Speed Controls, Exhaust Mufflers, Air Tank Fail Safe Systems, pneumatic Boosters
- Seat Cavity Filler
- Specialty Exterior Coatings
- Bonneted Design
- Live Loaded Packing System
- Specialty Gate Coatings



Optional Operators see [www.knifegates.com](http://www.knifegates.com) for details





**Fabricast Valve Company**  
1061 Industrial Way, Longview, WA 98632  
**Toll-Free** 1-877-264-2503  
**Local** (360) 425-0306 **Fax** (360) 425-0353  
[www.knifegates.com](http://www.knifegates.com)  
[sales@fabricastvalve.com](mailto:sales@fabricastvalve.com)

**DBB FIG 145-UHMW**  
**DBB FIG 40-MM**  
**DBB FIG 50-PS**





**Fabricast Valve Company**  
 1061 Industrial Way, Longview, WA 98632  
**Toll-Free** 1-877-264-2503  
**Local** (360) 425-0306 **Fax** (360) 425-0353  
 www.knifegates.com  
 sales@fabricastvalve.com

# FV 150-WG

FV 150-WG

Fabricast FV 150-WG is a cast Stainless Steel Bi-Directional Wedge Gate Valve. Designed and tested to MSS SP61 and ASME B16.5 specifications.

### Features

- Heavy Duty Cast CF8M 316 Stainless Steel Body, Bonnet, Gate, Packing Gland And Yoke. Standard Size Range Is 1/2"- 12"
- 285 PSI CWP Rated – ANSI CI150
- Drip Tight Bi-directional Shutoff To MSS SP61
- Precision CNC Machined Valve Body, Bonnet. Gate and Stem
- Braided PTFE Packing Is Standard 0-14 Ph Rating
- Stainless Steel Hardware
- PTFE Bonnet Gasket

### Options

Mechanical Lockouts  
 Bevel Gear Operator, Chainwheel



Fabricast Valve

Size	F-F	O.D.	center to top	H.W.	Bolt Circle	No. of Holes	Hole Size	Weight (lbs)
1/2"	4 1/4	3 1/2	7 1/2	4	2 3/8	4	5/8	
3/4"	4 5/8	3 7/8	7 1/2	4	2 3/4	4	5/8	
1"	5	4 1/4	9	5	3 1/8	4	5/8	
1 1/2"	6 1/2	5	11 1/2	5 1/2	3 7/8	4	5/8	
2"	7	6	13 1/4	7	4 3/4	4	3/4	44
2 1/2"	7 1/2	7	17 1/2	7	5 1/2	4	3/4	50
3"	8	7 1/2	17 3/8	8	6	4	3/4	55
4"	9	9	21 1/2	9	7 1/2	8	3/4	80
6"	10 1/2	11	29 1/4	12	9 1/2	8	7/8	130
8"	11 1/2	13 1/2	37 3/4	14	11 3/4	8	7/8	220
10"	13	16	45	16	14 1/4	12	1	348
12"	14	19	46	18	17	12	1	480
14"	15	21	60	18	18 3/4	12	1 1/8	600
16"	16	23 1/2	66 1/2	20	21 1/4	16	1 1/8	830
18"	17	25	73 3/4	20	22 3/4	16	1 1/4	900
20"	18	27 1/2	80 3/4	20	25	20	1 1/4	1150
24"	20	32	94	20	29 1/2	20	1 3/8	1520



**Fabricast Valve Company**  
 1061 Industrial Way, Longview, WA 98632  
**Toll-Free** 1-877-264-2503  
**Local** (360) 425-0306 **Fax** (360) 425-0353  
 www.knifegates.com  
 sales@fabricastvalve.com

# FV 150-SC

FV 150-SC

Fabricast FV 150-SC is a cast Stainless Steel Swing Check valve. Designed and tested to MSS SP61 and ASME B16.5 Specifications.

### Features

- Heavy Duty Cast CF8M 316 Stainless Steel Body, Inspection Cover and Gate Disc.
- Standard Size Range is 2" - 12"
- 285 PSI CWP Rated - ANSI CI 150
- Drip Tight Reverse Flow Seating To MSS SP61
- Precision CNC Machined Valve Body, Inspection Cover and Gate Disc.
- \* PTFE Top Plate Gasket

Note - For Horizontal Mounting Orientation Only



Fabricast Valve

Size	F-F	O.D.	center to top	Bolt Circle	No. of Holes	Hole Size	Weight (lbs)
2"	8	6	4-3/8	4-3/4	4	3/4	26
3"	9-1/2	7-1/2	5-1/2	6	4	3/4	48
4"	11-1/2	9	6-3/8	7-1/2	8	3/4	75
6"	14	11	8-1/2	9-1/2	8	7/8	120
8"	19-1/2	13-1/2	10	11-3/4	8	7/8	198
10"	24-1/2	16	12-1/4	14-1/4	12	1	330
12"	27-1/2	19	14-3/8	17	12	1	468
14"	Contact us						
16"	Contact us						
18"	Contact us						
20"	Contact us						
24"	Contact us						



**Fabricast Valve Company**  
1061 Industrial Way, Longview, WA 98632  
**Toll-Free** 1-877-264-2503  
**Local** (360) 425-0306 **Fax** (360) 425-0353  
www.knifegates.com  
sales@fabricastvalve.com

# FIG SAM-15/20

## CAST STAINLESS SAMPLING VALVE, 1½" NPT AND 2" NPT

FIG SAM-15/20

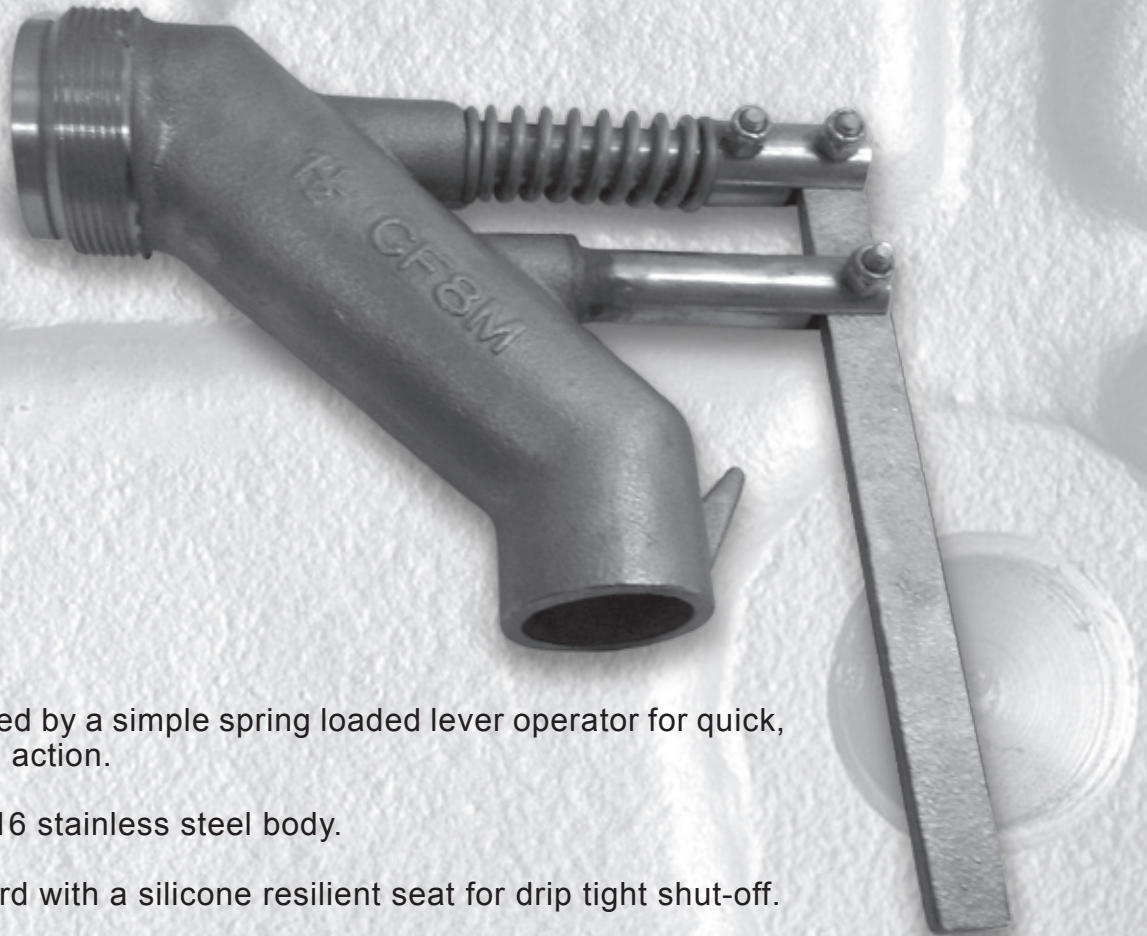

- Operated by a simple spring loaded lever operator for quick, precise action.
- Cast 316 stainless steel body.
- Standard with a silicone resilient seat for drip tight shut-off. seating capability.
- Stainless steel stem for corrosion resistance.
- Tested to MSS-SP-81 specifications

#### Used in these industries:

- Pulp & Paper

#### Technical data

- Range: Figure SAM-15, 1½" ID, 1½" NPT mounting threads.  
Figure SAM-20, 1½" ID, 2" NPT mounting threads.

**Ideal for applications in which content sampling of stock, slurry or other media is desired.**

Fabricast Valve





**Fabricast Valve Company**  
 1061 Industrial Way, Longview, WA 98632  
**Toll-Free** 1-877-264-2503  
**Local** (360) 425-0306 **Fax** (360) 425-0353  
 www.knifegates.com  
 sales@fabricastvalve.com

# FIG SAM-15/20

## LEVER OPERATOR

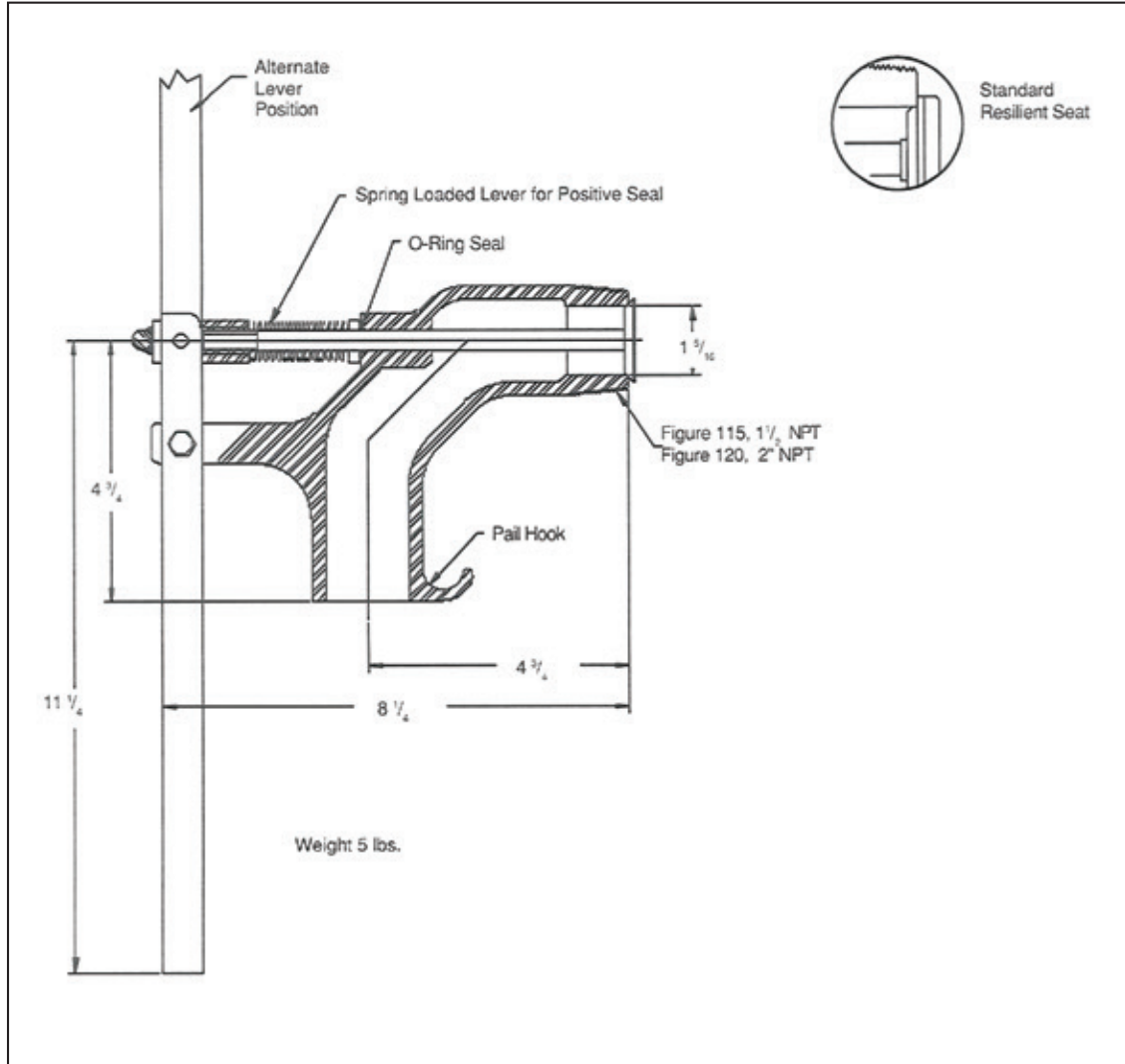

### MATERIALS

Body	Cast 316 SS
Disc / Rod	316 SS
Seat	Resilient Silicone
O-Ring	Viton®
Lever	304 SS

Viton® is a registered trademark  
 of DuPont Dow Elastomers.



**Fabricast Valve Company**  
1061 Industrial Way, Longview, WA 98632  
**Toll-Free** 1-877-264-2503  
**Local** (360) 425-0306 **Fax** (360) 425-0353  
www.knifegates.com  
sales@fabricastvalve.com

# FIG 40-50-61

## LEVER OPERATOR

FIG 40-50-61

Fabricast Valve

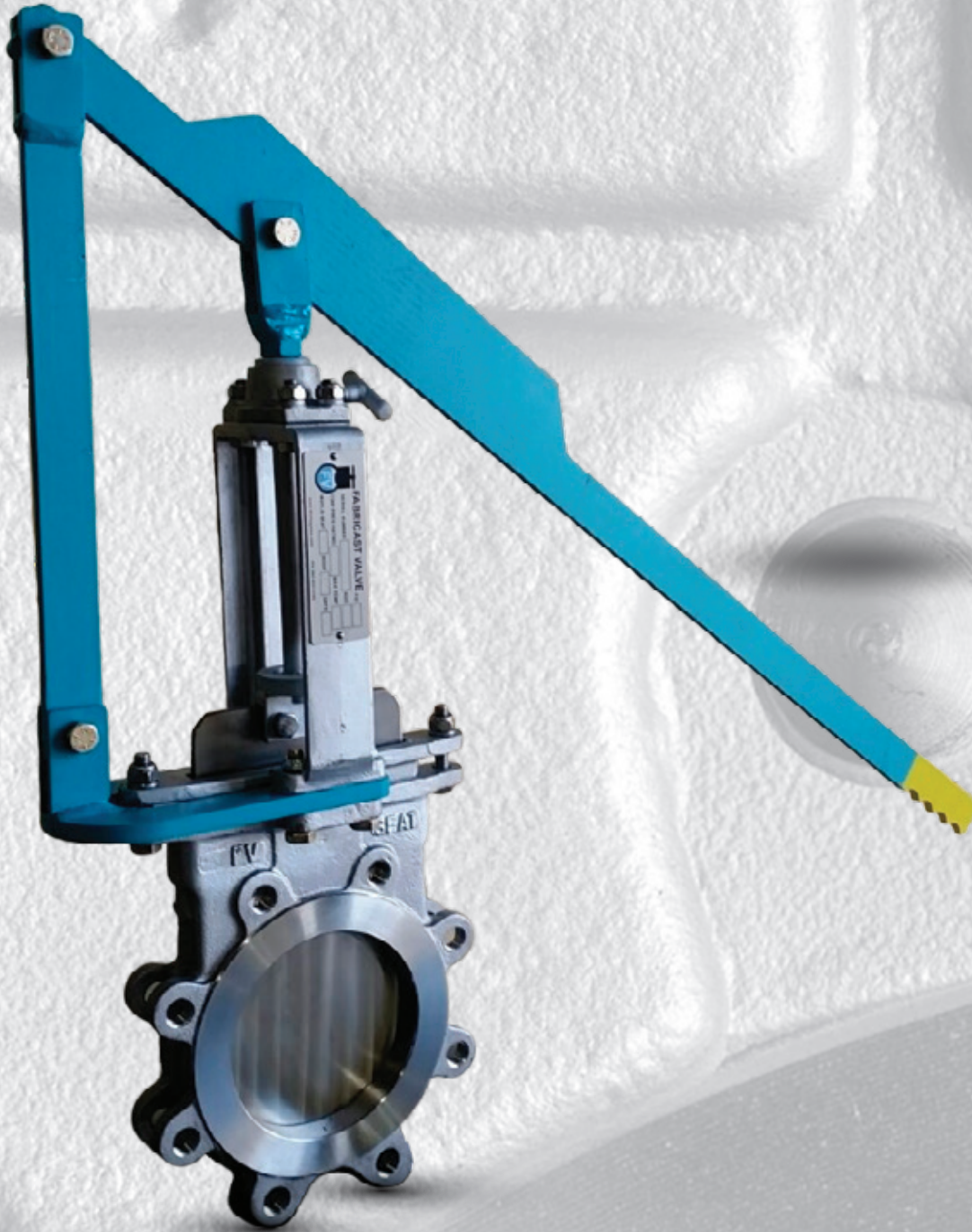



**Fabricast Valve Company**

1061 Industrial Way

Longview, WA 98632

toll free 1-877-264-2503 phone (360) 425-0306

fax (360) 425-0353 www.knifegates.com

# FIG 40-50-61

## LEVER OPERATOR

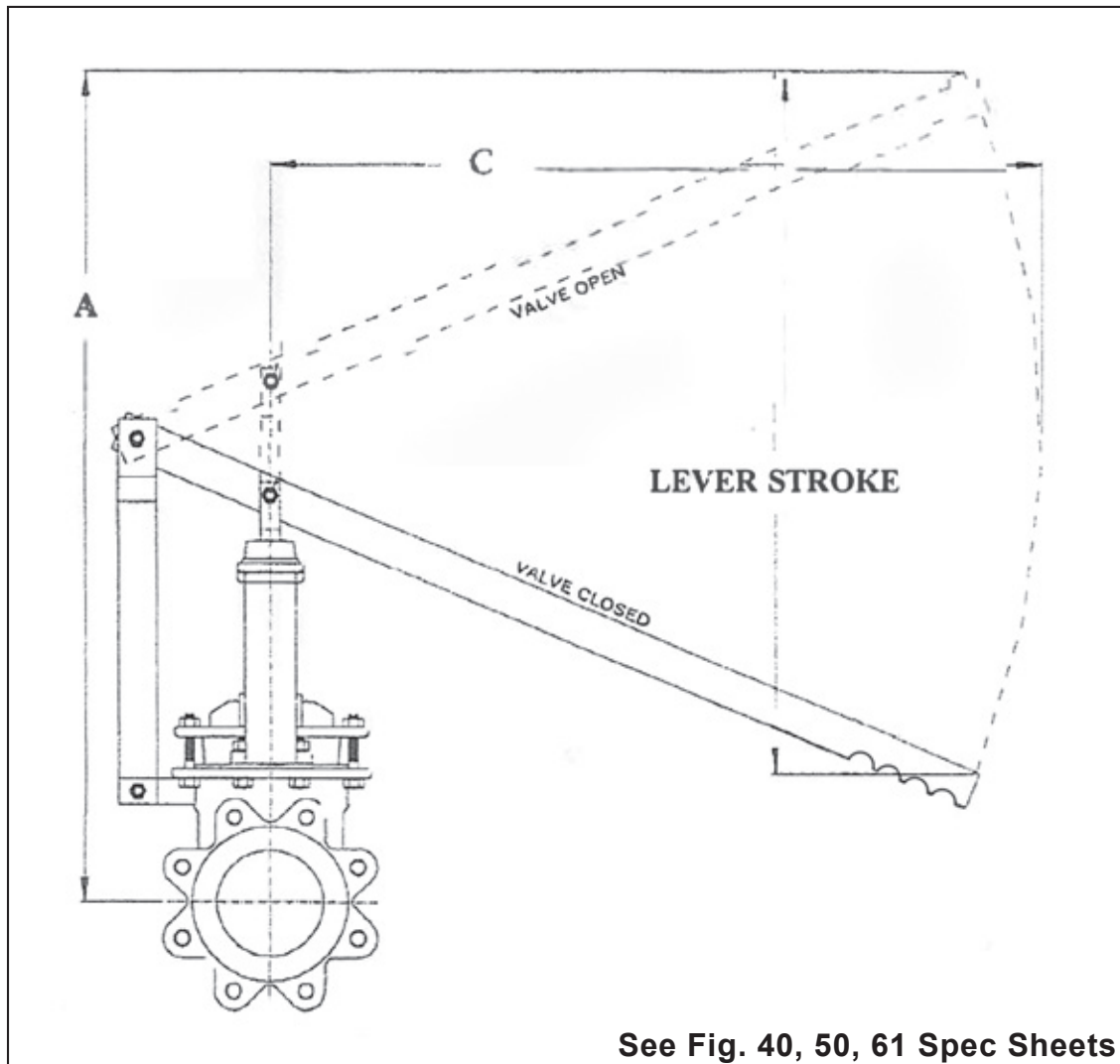

### LEVER DIMENSIONS

VALVE SIZE	A	LEVER STROKE	C
2"	26"	18"	19"
3"	31"	23"	25"
4"	36"	27"	31"
6"	46"	34"	37"
8"	52"	38"	40"



- Lever operators are not recommended on metal seated valve above 8" and resilient seated valves above 6"
- Lever operators can be either factory installed or supplied in kit form to be installed in the field.
- A stem "t" lock bolt is supplied on resilient seated valves to secure the gate in place for drip tight shutoff

*NOTE: LEVER DIMENSIONS ARE APPROXIMATE AND MAY VARY SLIGHTLY BETWEEN STYLES OF VALVES.*

Knife Gate Valves & Custom Fabrication / phone (360) 425-0306, fax (360) 425-0353



**Fabricast Valve Company**  
1061 Industrial Way, Longview, WA 98632  
**Toll-Free** 1-877-264-2503  
**Local** (360) 425-0306 **Fax** (360) 425-0353  
www.knifegates.com  
sales@fabricastvalve.com

# FIG 40-TIV

## CAST BODY TRANSMITTER ISOLATION VALVE



FIG 40-TIV

Fabricast Valve

- Cast stainless steel body, gate, packing gland and yoke.
- Ratchet operator standard. Lever operator available
- Fig. 40 Transmission Isolation Valve is designed for flush-mounting to tanks. Special tank side flange bolt circle allows close coupling to the tank flange.
- Gate designed to withstand full 150 PSI rated pressure as required by MSS-SP-81.
- Body cavity, seat configuration and beveled gate designed to provide shut-off capability in thick media such as pulp stock.
- Enclosed brass stem bushing provides reduced operating torque and protection of the stem bushing from harsh environments.
- 0-Ring resilient seat available.
- Precision machined stainless steel gate for superior seating capability.
- Stainless steel stem for corrosion resistance.
- Tested to MSS-SP-81 specifications

### Used in these industries:

- Pulp & Paper
- Industrial
- Food Processing
- Beverage
- Chemical



**Fabricast Valve Company**  
1061 Industrial Way, Longview, WA 98632  
**Toll-Free** 1-877-264-2503  
**Local** (360) 425-0306 **Fax** (360) 425-0353  
www.knifegates.com  
sales@fabricastvalve.com

# FIG 7 / 27

FIG 7 / 27

The Fabricast FIG 7/27 is a fabricated and welded Swing Check Valve. Designed and tested to MSS SP61 and ASME B16.5 specifications.

#### Features

- Heavy duty fabricated 304 or 316 stainless steel body and gate disc. Standard range is 2" - 48"
- 150 PSI CWP rated up to 24".

Drip tight reverse flow seating to MSS SP61

- Precision CNC machined valve body and gate disc.
- Economy design is fully enclosed.

Note - For horizontal mounting orientations

#### Options

- Other Alloys - 317L, Duplex 2205, 904L
- Removable inspection cover and outside shaft with or without counterweight.



**FIG 7**

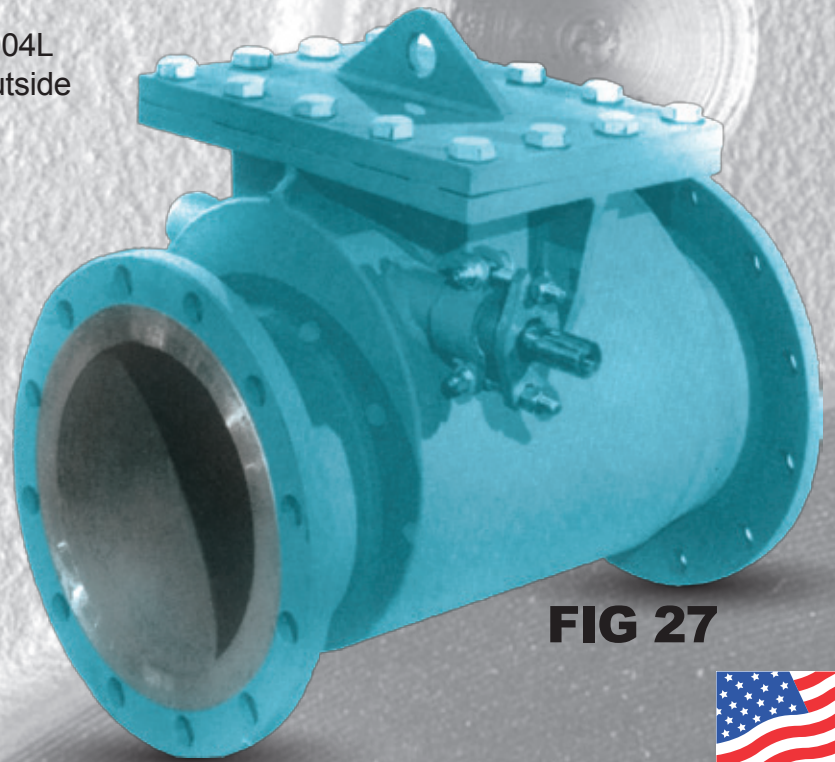

**FIG 27**

Fabricast Valve

**Previous Model**  
**FV-150-SCV**





**Fabricast Valve Company**  
 1061 Industrial Way, Longview, WA 98632  
**Toll-Free 1-877-264-2503**  
**Local (360) 425-0306 Fax (360) 425-0353**  
 www.knifegates.com  
 sales@fabricastvalve.com

# FIG 7 / 27

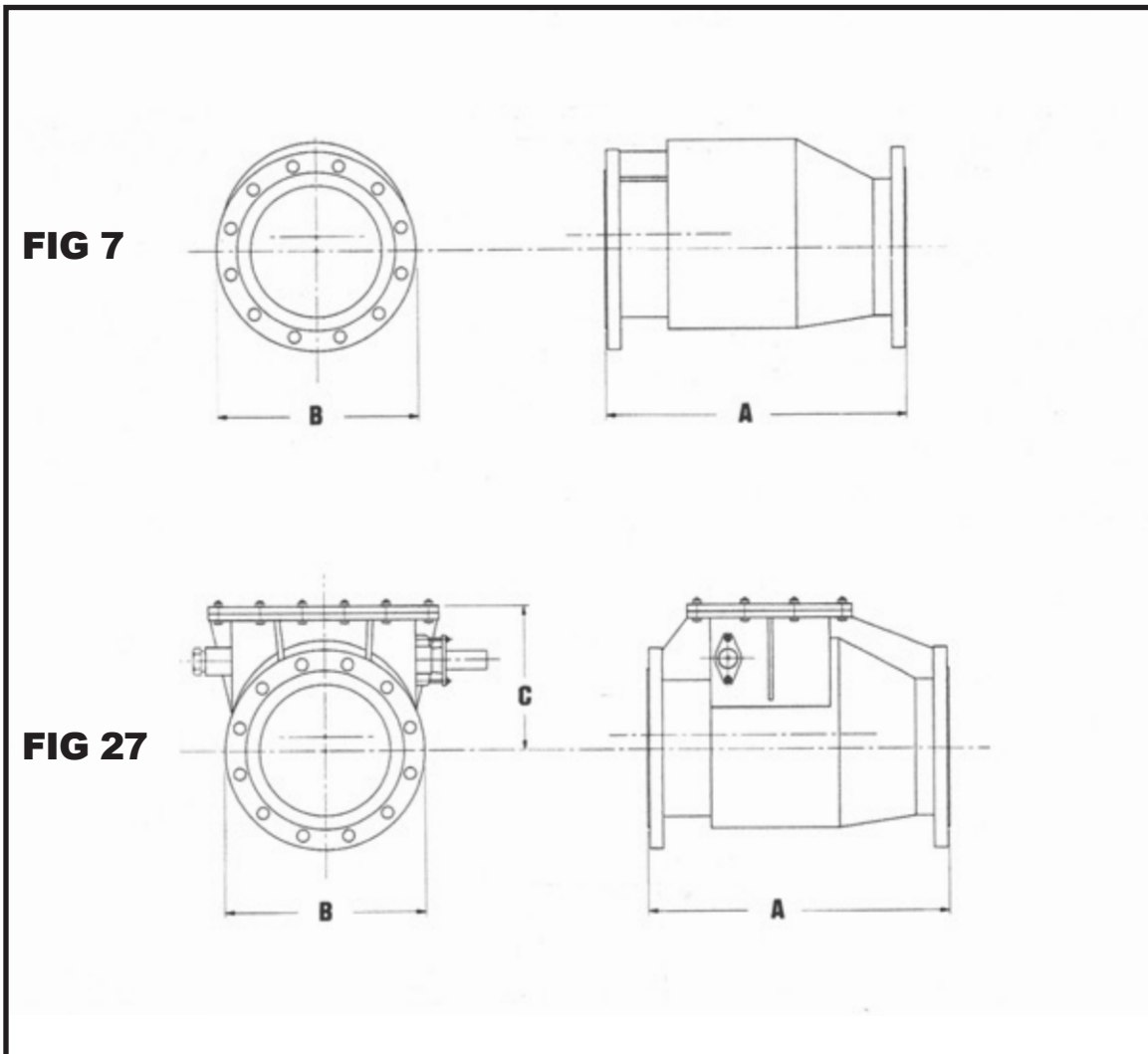

SIZE	3	4	6	8	10	12	14	16	18	20	24
F-F	9.5	11.5	16	19.5	24.5	27.5	31	36	38.5	38.5	51
MIN	7	9	10.75	14.63	16.38	18.63	21.38	23.38	24.25	26	33
FLG	7.5	9	11	13.5	16	19	21	23.5	25	27.5	32
7 WT	22	35	50	99	135	200	245	290	350	425	635
27 WT	49	55	83	159	231	387	419	512	670	710	819

# Fabricast Valve



## Service Rates

For set-up, Field Service & Shop Time

	Daily Rates	Standard (Hourly)	Overtime (Hourly)
Monday-Friday	\$1,500.00	\$187.50	\$281.25
Saturday	\$2,100.00	\$262.50	\$393.75
Sunday/Holidays	\$3,000.00	\$375.00	\$562.50
Shop Time		\$100.00	\$150.00

## Terms and Conditions:

- Daily Rates cover an eight (8) hour period between the hours of 8:00 a.m. and 5:00 p.m. Monday - Friday
- Work performed before 8:00 a.m. and after 5:00 p.m. will be charged at the appropriate overtime rate.
- Field Service and set-up charges are from the time of departure until the return of our service representative. Transit hours after 5:00 p.m. will be charged at the appropriate standard rate.
- Field service and set-up charges include mid-day lunch meal break.
- Lodging and travel expenses to and from the point of origin (Longview, WA) will be charged at cost.
- Charges for required parts are net prices. Shipping charges will be billed at cost.
- A minimum of 4 hours will be charged for field service work.
- Service work is scheduled on a first-come, first-serve basis.
- Set-up and training requires a two week lead time minimum.
- Service techs carry standard PPE. Safety equipment needed for confined space or recovery, etc. needs to be customer provided.

Please call if you have any questions.



**Fabricast Valve Company**  
1061 Industrial Way, Longview, WA 98632  
**Toll-Free** 1-877-264-2503  
**Local** (360) 425-0306 **Fax** (360) 425-0353  
[www.knifegates.com](http://www.knifegates.com)  
[sales@fabricastvalve.com](mailto:sales@fabricastvalve.com)