

Instruction, Operation and Maintenance Manual
DOUBLE BLOCK AND BLEED

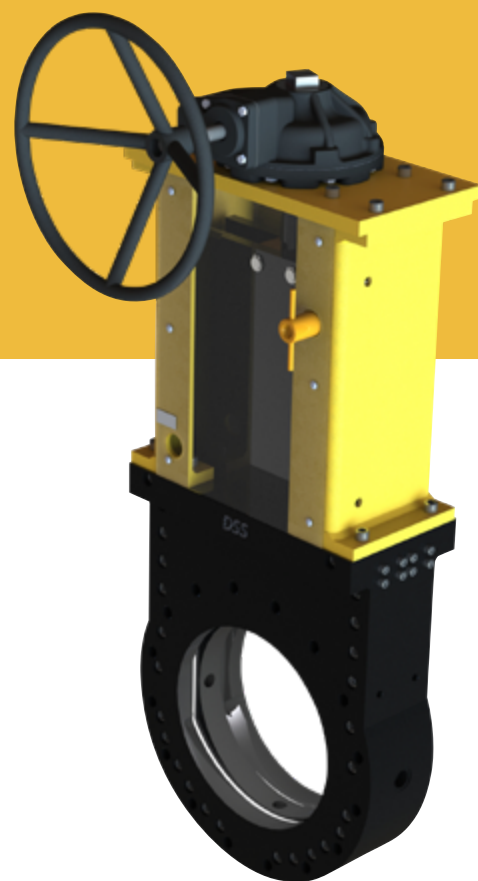

TABLE OF CONTENTS

1	Introduction	4
	1.1 Disclaimer	4
	1.2 Contact Information	4
2	Features and Benefits	7
3	Parts Diagram and List	8
4	Dimensions	10
5	Installation Guidelines	12
6	Operation Guidelines	14
7	Maintenance Guidelines	15
	7.1 Replacing the dust covers	15
	7.2 Repacking the primary and secondary seals	15
	7.3 Replacing the primary and secondary seals	16
8	Flange Bolts and Studs	17
9	Design Specs, Material List and Torque Values	18
10	Troubleshooting	19
11	Ordering Information	20

Thank You for Choosing DSS Valves

At DSS Valves, each day we take pride in getting one step closer to mastering the design and manufacture of the preeminent Severe Service Knife Gate Valves on the market.

We're excited that you've decided to join us on this journey through purchasing the most advanced Double Block and Bleed valve available.

To make sure you achieve maximum service life and trouble free operation from your investment, we've put together this **instruction, operation and maintenance manual** that highlights the key features and benefits of your valve, as well as important information for valve upkeep.

Should you have any questions, please feel free to contact us directly.

Sincerely,

The Team at DSS Valves

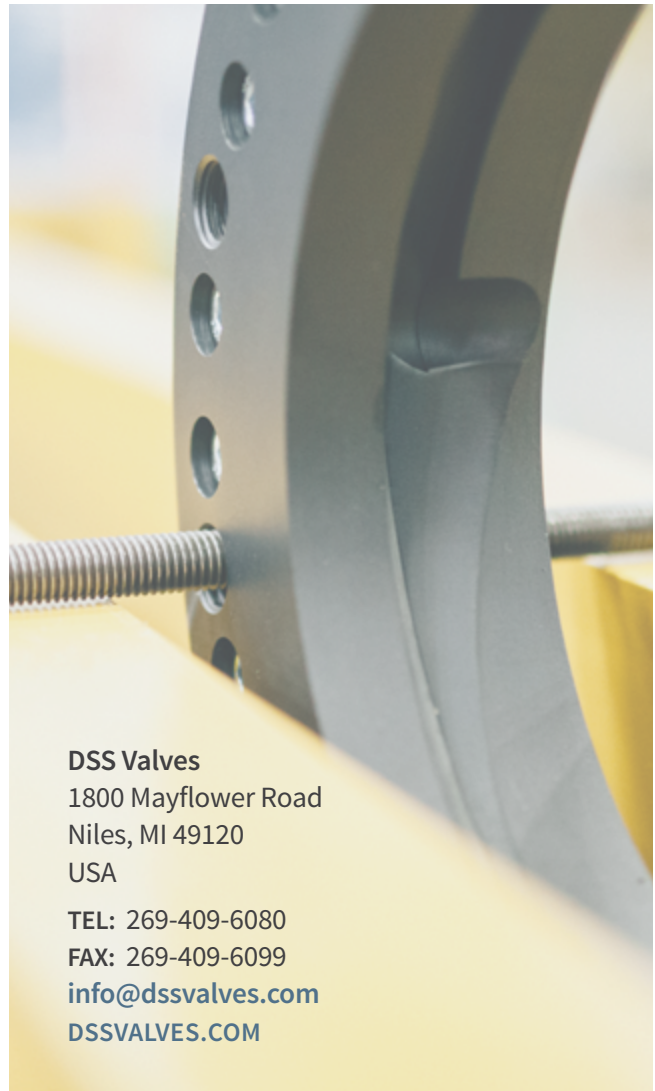

DSS Valves

1800 Mayflower Road
Niles, MI 49120
USA

TEL: 269-409-6080

FAX: 269-409-6099

info@dssvalves.com

DSSVALVES.COM

DISCLAIMER:



Working with industrial valves is inherently dangerous, and appropriate precautions should be taken at all times. Only skilled professionals with qualified experience using the tools and equipment required should be involved.

Proper understanding of the system and application the valve is being inserted into is a must.



Safety equipment should always be worn during the process, and should include but is not limited to steel toed boots, hard hats, ear and eye protection, and high visibility clothing.

Any alteration or modification to the valve supplied by DSS Valves must receive written approval. DSS Valves is not responsible for consequential damages should this written approval not be obtained.



DBB

Double Block and Bleed



Double Block and Bleed

Features and Benefits

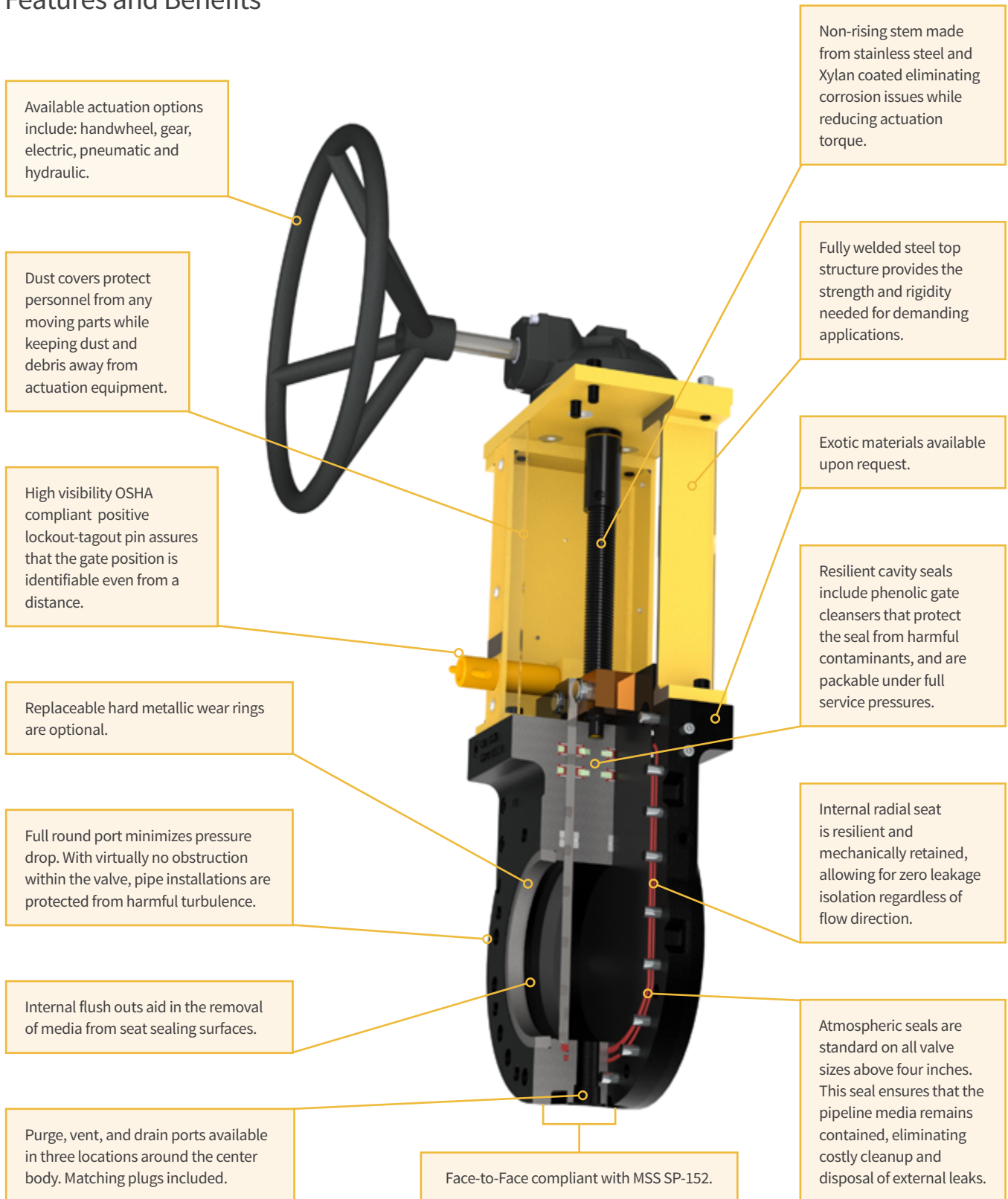

Available actuation options include: handwheel, gear, electric, pneumatic and hydraulic.

Dust covers protect personnel from any moving parts while keeping dust and debris away from actuation equipment.

High visibility OSHA compliant positive lockout-tagout pin assures that the gate position is identifiable even from a distance.

Replaceable hard metallic wear rings are optional.

Full round port minimizes pressure drop. With virtually no obstruction within the valve, pipe installations are protected from harmful turbulence.

Internal flush outs aid in the removal of media from seat sealing surfaces.

Purge, vent, and drain ports available in three locations around the center body. Matching plugs included.

Face-to-Face compliant with MSS SP-152.

Non-rising stem made from stainless steel and Xylan coated eliminating corrosion issues while reducing actuation torque.

Fully welded steel top structure provides the strength and rigidity needed for demanding applications.

Exotic materials available upon request.

Resilient cavity seals include phenolic gate cleansers that protect the seal from harmful contaminants, and are packable under full service pressures.

Internal radial seat is resilient and mechanically retained, allowing for zero leakage isolation regardless of flow direction.

Atmospheric seals are standard on all valve sizes above four inches. This seal ensures that the pipeline media remains contained, eliminating costly cleanup and disposal of external leaks.

Double Block and Bleed

Parts Diagram and List

Parts in this diagram and list represent an 8" Class 150 DBB. Parts may vary slightly depending on order placed.

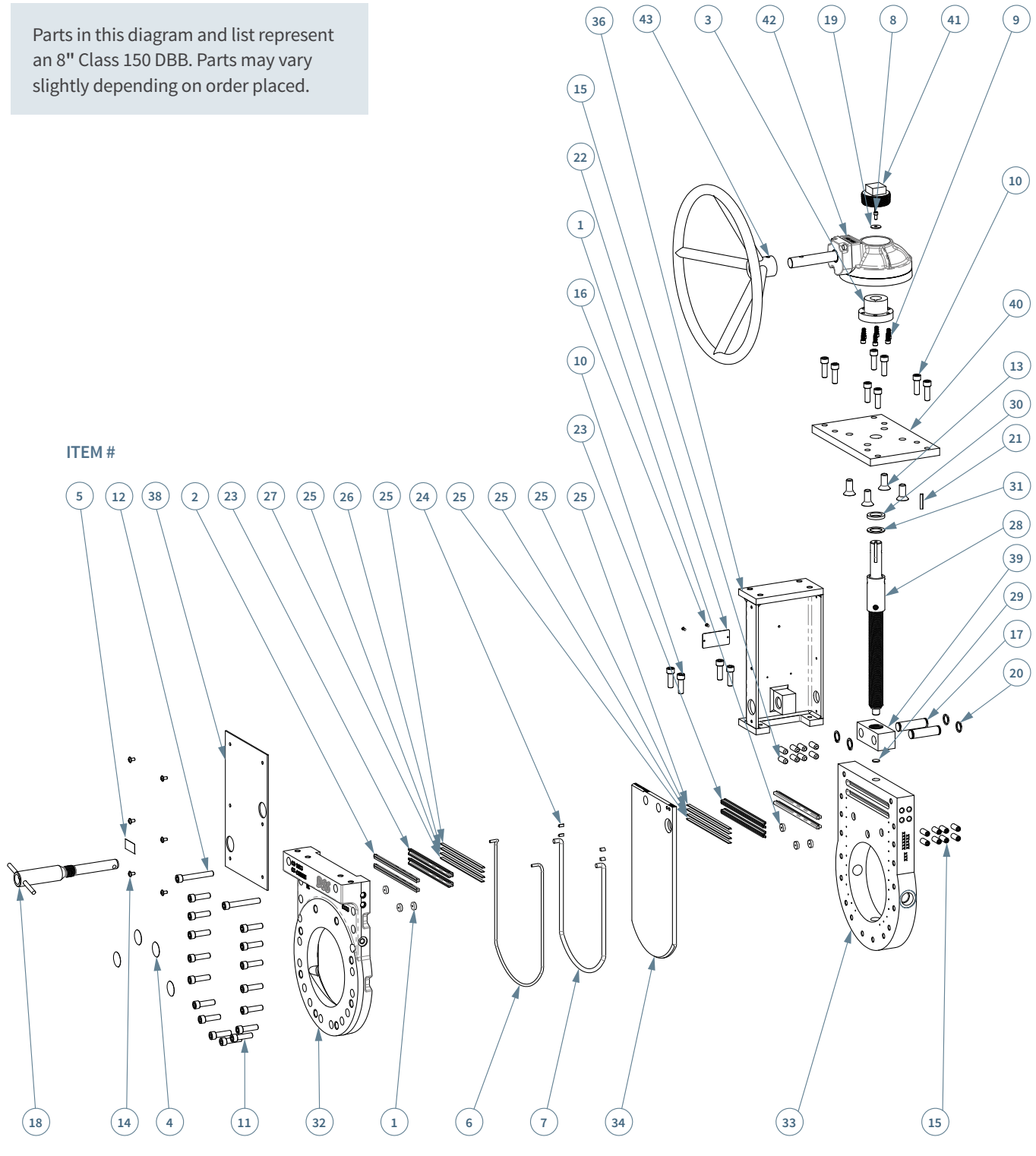

ITEM #	PART NUMBER	QTY	DESCRIPTION
1*	000-191-00-093	12	Disc, Gate Glide
2*	000-195-00	2	Packing
3	01-410-113-081	1	Drive Hub, Bevel Gear 3
4	20-150-3-1	8	Decal, Blind Hole Warning
5	21-102-3-1	1	Decal, Locator Pin Warning
6*	40-006-036-095	2	Seal, Secondary
7*	40-010-032-097	2	Seal, Primary
8	50-025-20-0050-089	1	SHCS, 1/4-20 X .500
9	50-031-18-0075-089	6	SHCS, 5/16-18 X .750
10	50-050-13-0150-089	16	SHCS, 1/2-13 X 1.500
11	50-050-13-0175-055	32	SHCS, 1/2-13 X 1.75
12	05-050-13-0350-055	4	SHCS, 1/2-13 X 3.50
13	51-063-11-0150-089	4	FHSCS, 5/8-11 X 1.500
14	52-025-20-0050-088	12	FBHSCS, 1/4-20 X .500
15	55-050-13-0125-088	16	SSS, 1/2-13 X 1.250
16	65-125-251-312-2	2	Pop-Rivet, Domed Head, 1/8 Dia. X .251"-.312" Range
17	67-088-0284-2	2	Pin, Clevis
18	68-150-0750-1	1	Pin, Positive Lockout-Tagout
19	81-025-1	1	Washer, 1/4" X 1.00" OD Fender
20	90-087-2	4	Ring, Extra Thick Retaining
21	95-025-150-1	1	Key, 1/4" Square

ITEM #	PART NUMBER	QTY	DESCRIPTION
22	99-150-300-2	1	Tag, Identification
23*	108-172-00-095	8	Seal, Cavity
24*	108-181-00-093	8	Seal, Quarter
25*	108-186-00-090	12	Blade, Seal Scraper
26*	180-187-00-090	2	Blade, Secondary Seal Scraper
27*	108-189-00-090	2	Blade, Primary Seal Scraper
28	108-270-00-054	1	Screw, Assembly
29	108-274-00-069	1	Disc, Thrust
30	108-277-00-054	1	Washer, Thrust
31	108-280-00-069	1	Bearing, Thrust
32	7108-015-00-006-J	2	Body, Double Block and Bleed Front
33	7108-030-00-053-J	1	Body, Double Block and Bleed Center
34	7108-050-00-053-K	1	Gate, Double Block and Bleed
35	7108-051-00-53-K	1	Gate, Double Block and Bleed
36	7108-220-00-076	1	Yoke, Double Block and Bleed Left
37	7108-230-00-076	1	Yoke, Double Block and Bleed Right
38	7108-240-00-075	2	Cover, Double Block and Bleed Dust
39	7108-260-00-062	1	Nut, Screw
40	7108-410-00-076	1	Plate, Bevel Gear 3
41	9000-250	1	2-1/2 Hollow Pipe Plug, B16.14
42	BG3	1	Bevel Gear Reducer, 3:1
43	HWRR18 11-322	1	Handwheel, 18" Round Recessed

*Recommended spare parts. Available in standard repair kit.

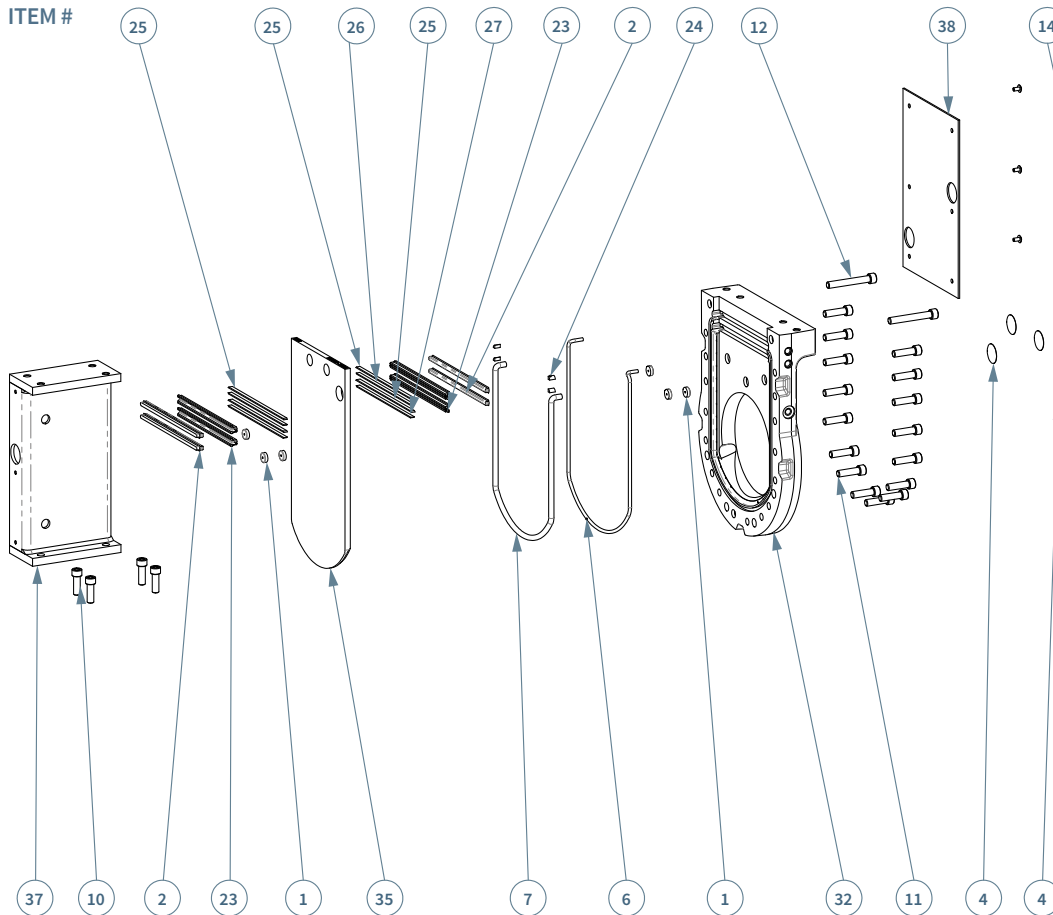

Double Block and Bleed Dimensions

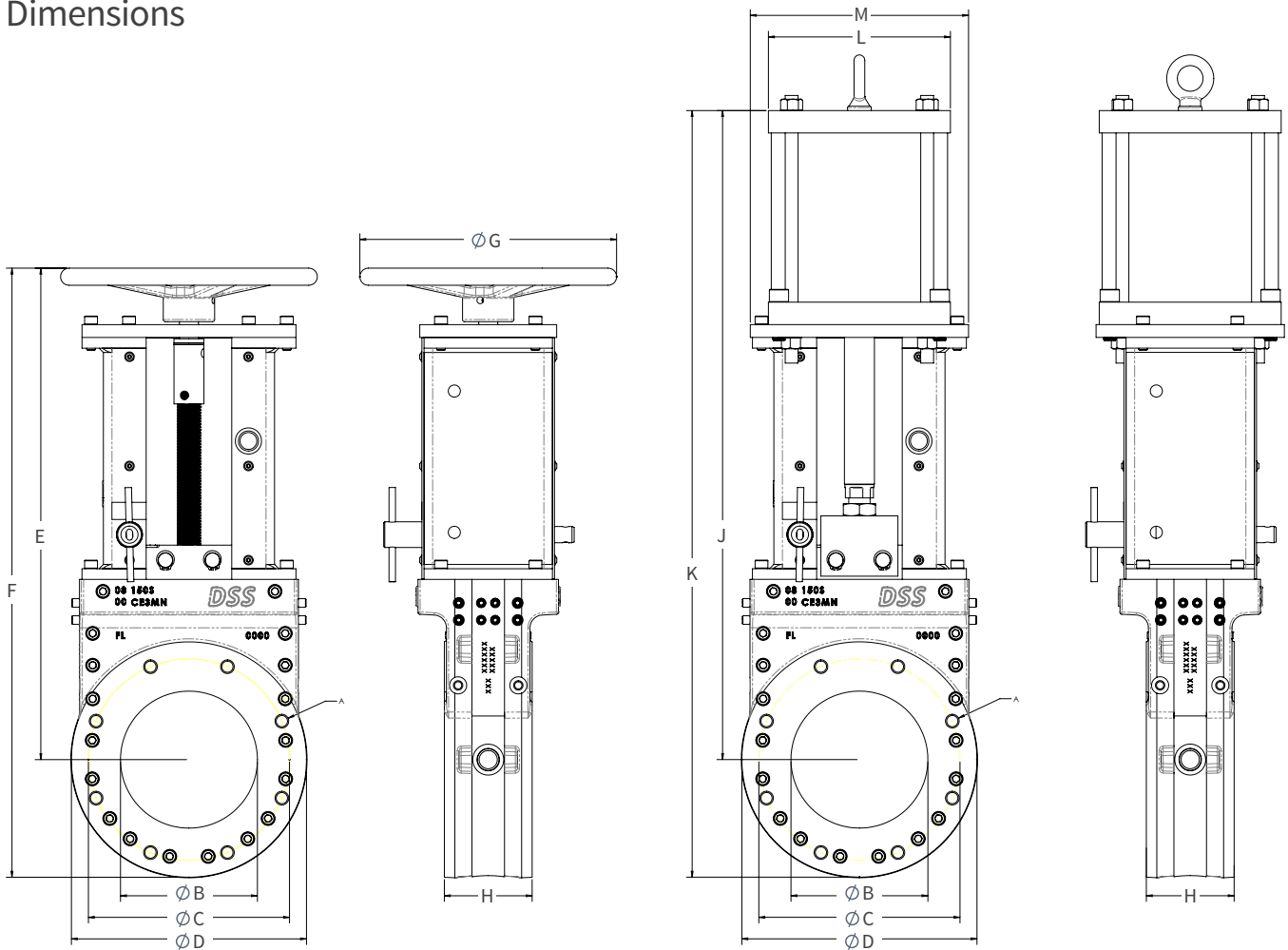

DBB SSKGV CLASS 150 DIMENSIONS

Valve Size		Flange							Dimensions								Standard Pneumatic Cylinder Bore**
		Bolting			Dimensions				Dimensions								
NPS*	DN [mm]	Class	QTY.	ØA (THREAD)	ØA (CLEARANCE)	ØB	ØC	ØD	E	F	ØG	H	J	K	L	M	
2	50	150	4	5/8-11	0.75	1.88	4.75	6.00	14.60	17.60	10.00	3.75	18.57	21.57	4.50	5.50	4.00
3	75		4	5/8-11	0.75	2.88	6.00	7.50	16.60	20.35	10.00	3.75	21.76	25.51	4.50	5.50	4.00
4	100		8	5/8-11	0.75	4.00	7.50	9.00	18.58	23.08	10.00	3.75	24.76	29.26	6.50	6.25	6.00
6	150		8	3/4-10	0.88	6.00	9.50	11.00	23.29	28.79	12.00	4.00	31.93	37.43	8.50	10.25	8.00
8	200		8	3/4-10	0.88	8.00	11.75	13.50	29.33	36.08	12.00	5.13	37.91	44.66	10.63	12.75	10.00
10	250		12	7/8-9	1.00	10.00	14.25	16.00	33.19	41.19	12.00	5.13	43.64	51.64	12.75	14.50	12.00
12	300		12	7/8-9	1.00	12.00	17.00	19.00	32.64	42.14	16.00	5.75	50.65	62.52	14.75	16.75	14.00
14	350		12	1-8	1.12	13.25	18.75	21.00	-	-	-	5.75	55.81	66.34	17.00	19.00	16.00
16	400		16	1-8	1.12	15.25	21.25	23.50	-	-	-	6.50	62.08	73.87	17.00	21.75	16.00
18	450		16	1 1/8-8	1.25	17.25	22.75	25.00	-	-	-	6.50	68.08	80.63	17.00	24.00	16.00
20	500		20	1 1/8-8	1.25	19.25	25.00	27.50	-	-	-	8.13	74.83	88.58	21.00	26.25	20.00
24	600		20	1 1/4-8	1.38	23.25	29.50	32.00	-	-	-	8.13	86.95	102.95	23.00	30.25	22.00
30	750		28	1 1/4-8	1.38	29.25	36.00	38.75	-	-	-	12.25	103.58	122.96	-	36.25	26.00
36	900		32	1 1/2-8	1.63	35.25	42.75	46.00	-	-	-	14.75	125.70	148.70	-	43.00	32.00

*Please consult DSS Valves or an authorized distributor for bore sizing, actuator sizing or specialty orders. Larger sizes and higher pressure classes are available upon request.

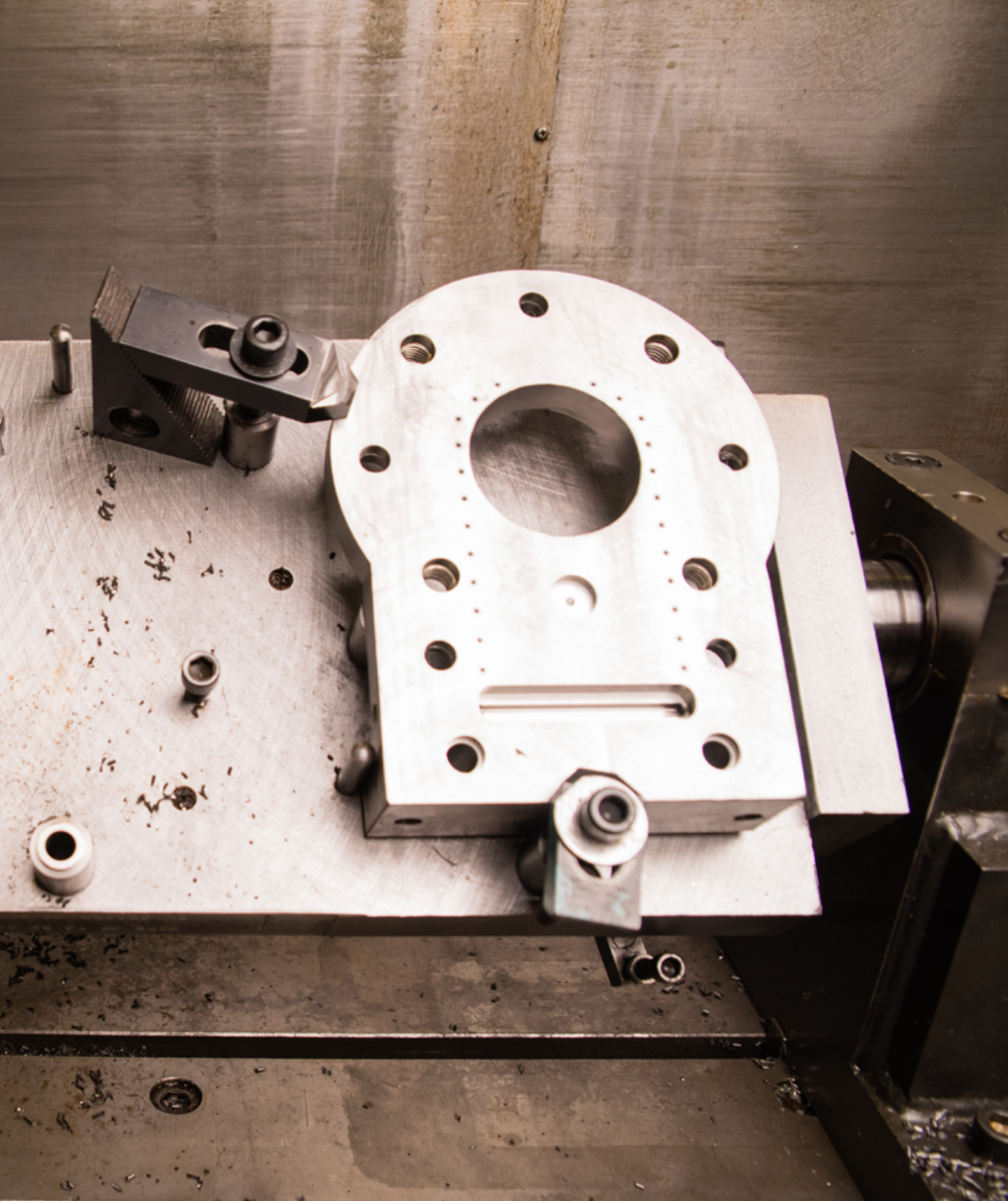

Installation Guidelines

STORAGE

Prior to installation, keep this valve in the factory applied shrink wrapping and store in a dry environment.

TRANSPORTATION

The safest and easiest way to move this valve is to leave it in the supplied shipping crate and use a forklift and/or pallet jack as appropriate. When the time comes to unpack and move it without the crate, be sure to **attach proper lifting straps or covered chains** in the following positions:

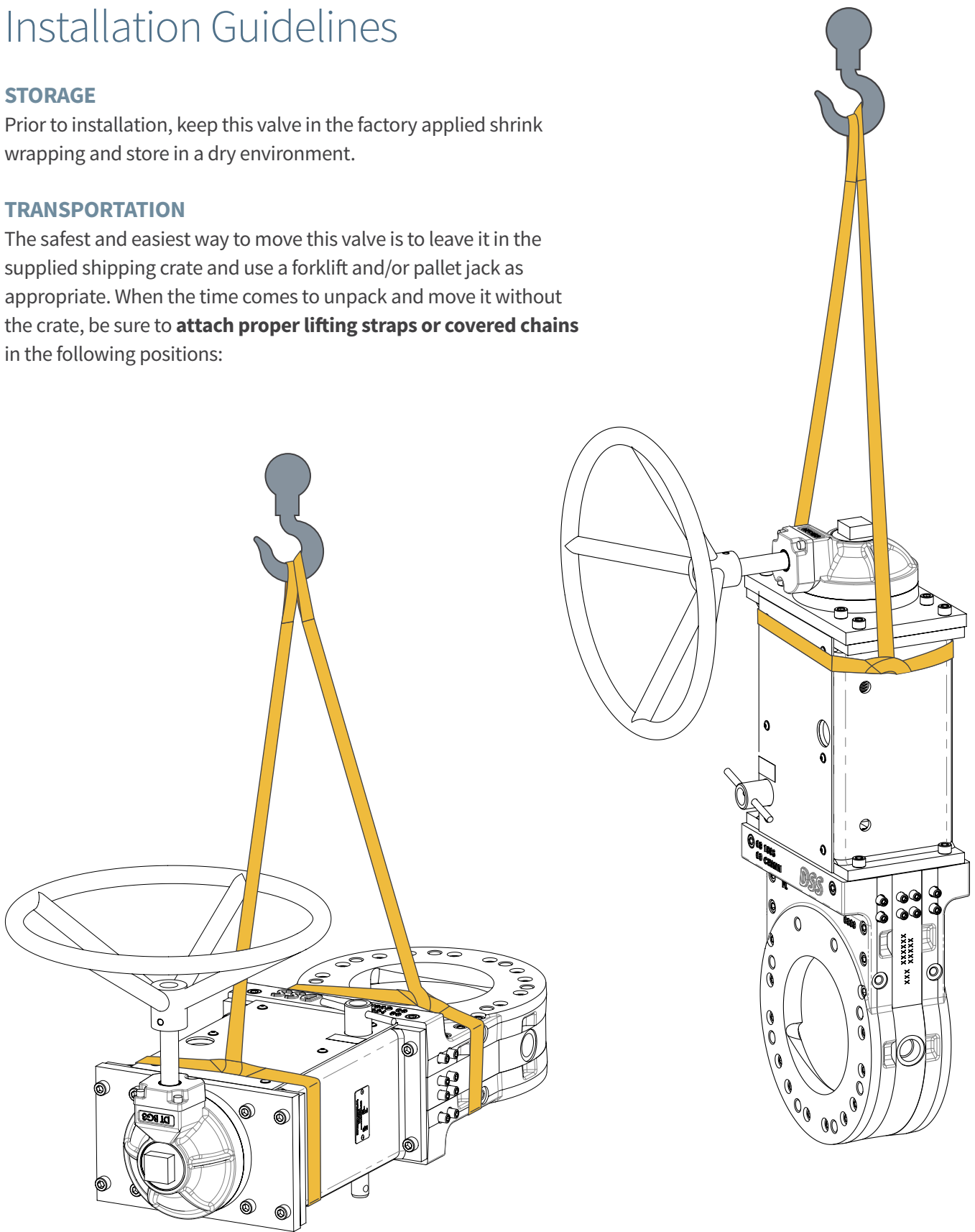

CLEANING THE INSTALLATION SITE

Remove dust, dirt, debris, and any applied corrosion protection from pipeline and flanges before installing the valve.

FLOW DIRECTION AND INSTALLATION POSITION

This valve can be installed in any required position, and comes factory tested for zero leakage isolation in either direction.

For valves supplied with Ni-Hard wear rings, bore reducers, or other body inserts the flow direction is more critical. Ensure that the inserts are on the upstream/high pressure side of the valve, and that the orange arrow point in the direction of the flow.



When installing, remember to make sure at least one side of the valve body is accessible so that the repacking screws can be adjusted.

PIPELINE ALIGNMENT

Inaccurately aligned pipelines can cause stress to the valve body. Be sure to have any misalignments corrected before installation of the valve.

MATING FLANGES

Always check to make sure the mating flanges have a proper seal – the bolts used in the blind flange holes in the valve’s chest area should not touch the bottom of the holes. DSS Valves come standard with tapped flange holes, however through bolts are available upon request.

If further technical advice is required, feel free to consult DSS Valves directly: info@dssvalves.com

INSTALLING INTO A PIPELINE:

Note: This valve can be installed with the actuator in any position, with no need to support the actuator.

1. Bolt the valve to the mating flange using the proper size fasteners. DSS recommends the use of studs to ensure the full thread engagement of tapped holes. If using stainless steel fasteners, lubricate to prevent galling.
2. Adjust fastener length for mating flange thickness, gaskets, and support rings.
3. Tighten the flange bolts in an alternating sequence.
4. Prepare the valve for hydro testing.

Hand Wheel Operated or Bevel Gear Operated Valves: no action required.

Air Cylinder-operated valves—connect the control air supply to the air cylinder. Standard configured valve required pressure is 50–100 psi.

Hydraulic Cylinder-operated Valves—connect control hydraulic supply to the hydraulic cylinder. Standard configured valve required pressure is 500–1000 psi.

Electric-operated Valves—connect electric supply according to instructions.

5. Hydro test the system. For more information, see the repacking the primary and secondary seals section in the maintenance portion of this manual.

Note: After the valve is installed and is under pressure, be sure to observe closely for the first 24 hours. Occasionally a small leak may occur if the gate seal integrity was impacted by rough transport, lengthy storage, or extreme temperature variations. This can be remedied by tightening the packing screws accordingly.

Operation Guidelines

LOCKOUT-TAGOUT INSTRUCTIONS

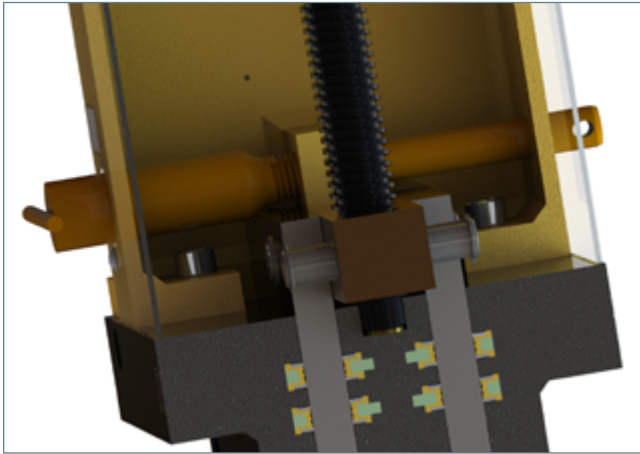

Closed lockout-tagout procedure:

1. Actuate the valve to the fully closed position isolating upstream flow from downstream piping.
2. Insert orange lockout-tagout pin through bottom hole of the left yoke from the front body side. Lockout-tagout pin must pass through first wall of the yoke over the top of the gate and then into the center pin block where it will be threaded up against the beveled seat of the gate. Ensure that the pin is tightened against the gate guaranteeing a positive shutoff in the closed position.
3. A hole is provided on the back body side of the pin for attaching lockout-tagout hasps, padlocks or other similar items.
4. The double block and bleed valve is now fully locked out in the closed position. Do not attempt to open the valve as this may compromise the bubble tight seal and damage the pin. The pin will ensure that the gate does not unseat under normal pipeline working pressures.
5. To actuate the valve after lock and tag condition is no longer required, unscrew the pin and completely remove from yoke.
6. The valve can now be actuated when needed.

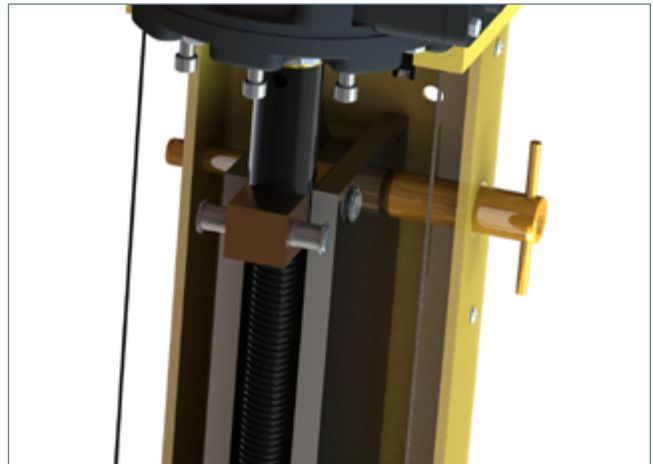

Open lockout-tagout procedure:

1. Actuate the valve to the fully open position allowing upstream flow to downstream piping.
2. Insert orange lockout-tagout pin through top hole of the right yoke from the front body side. Lockout-tagout pin must pass through first wall of the yoke then into the gate where it will be threaded up against the beveled seat of the gate. A hole is provided on the back body side of the pin for attaching lockout-tagout hasps, padlocks or other similar items.
3. The double block and bleed valve is now fully locked out in the open position.
4. To actuate the valve after lock and tag condition is no longer required, unscrew the pin and completely remove from yoke.
5. The valve can now be actuated when needed.

CYCLING

This Double Block and Bleed can be cycled at any speed and as frequently (or infrequently) as needed. As you may be using a hand wheel, chain wheel, ratchet handle, bevel gear, gear reduction, pneumatic, hydraulic, or electric actuator to open and close this valve, we recommend following the standard procedures that accompany these actuation devices.

Maintenance Guidelines

REPLACING THE DUST COVERS

Dust covers are critical for reducing valve maintenance as they remove environmental contamination of moving parts. They also eliminate pinch points on automatically operated valves. Make sure these covers are not removed. If a dust cover is broken or cracked, replacement parts can be ordered and easily replaced by following these steps:

1. Remove the stainless-steel screws with 5/32 Allen key.
2. Replace dust cover.
3. Tighten stainless-steel screws.
4. Repeat on other side of the valve.

REPACKING THE PRIMARY AND SECONDARY SEALS

Repacking the primary and secondary seals will ensure package area leakage is kept to a minimum. Because of the design, this can be done while the system is under full pressure, with an open or closed valve.

Repacking with no pressure:

1. Remove one of four stainless steel screws on the side of the valve.
2. Push one or two packing pellets into the hole.
3. Tighten the screw until snug. If you can tighten the screw until it meets the valve body, back the screw out and add an additional pellet. The goal is to have the screw sticking out (1/2 inch) at the end of the process.
4. Repeat with remaining three screws.

Repacking while line is under full pressure:

Simply tighten screws with 1/4 or 5/16 Allen key, depending on valve size. Bags of packing pellets are sold separately.

Tip: Try to pack the same number of pellets into each packing hole. Resist the urge to overpack, as excessive numbers of pellets can impact the actuation of the valve.

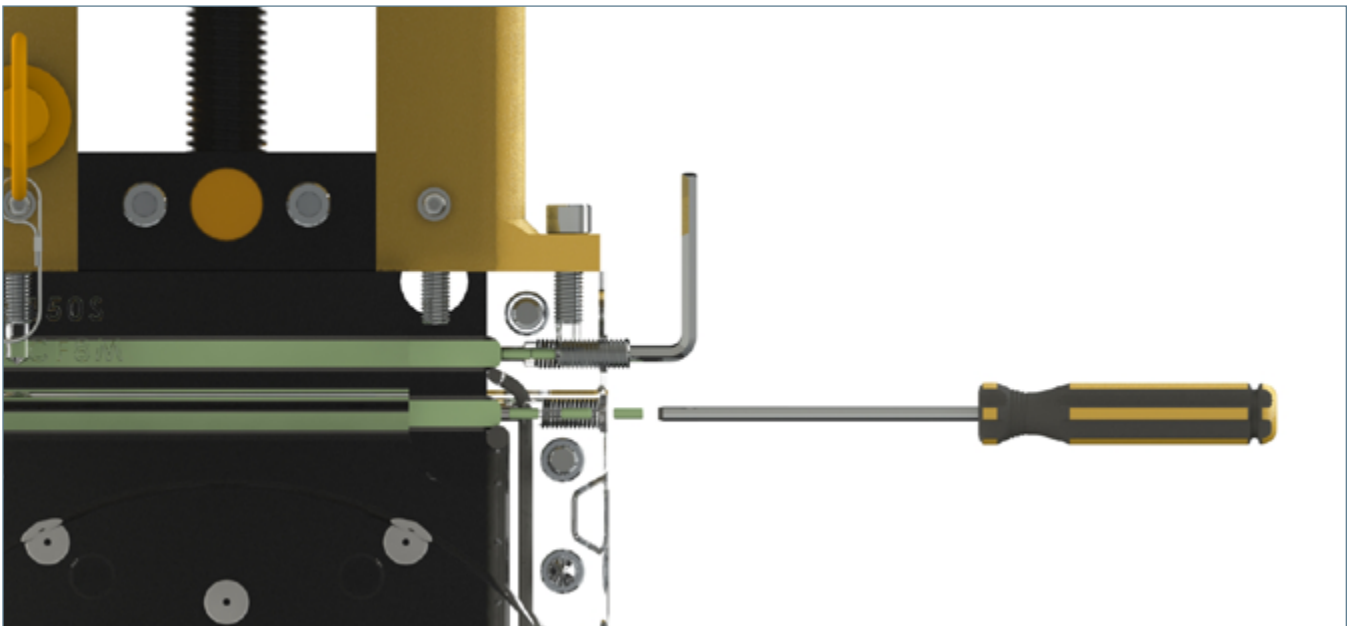

Maintenance Guidelines

REPLACING THE PRIMARY AND SECONDARY SEAL

Damaged or worn primary and secondary seals need to be replaced. Seal kits can be purchased separately if this is being done on site. Alternatively, the valve can be sent back to the DSS factory for maintenance.

If you choose to do this yourself, replacement kits include a resilient o-ring, primary and secondary seals, TFE packing pellets, and scraper blades.

Warning: This is a labor-intensive operation, which should be conducted by a qualified valve technician using the appropriate safety equipment.

1. Remove the dust covers, actuator, and top structure from the valve bodies.
2. Remove the body screws, and then separate the bodies.
3. Note the position of the existing seals, and then gently pry out the old seals.
4. Remove any debris around the sealing area on the interior of the valve body.
5. Prep the replacement resilient primary or secondary seal by removing any packaging material.
6. The stranded green packing material must remain in the pocket of the resilient primary or secondary seal. If stranded material falls out, simply push it back into place.
7. Place the resilient seal in the machined seal groove on the body half by starting at one end of the groove.
8. Once the new primary or secondary seal is installed in the groove, insert the plastic scrapers between the seal and the side of the machined groove. This process should be repeated for each seal in each body.
9. On the front body half (with the blade pocket), insert the end of the resilient o-ring seal into the tuck hole below in the blade pocket. The o-ring seal should seat securely on the bottom of the tuck hole.
10. Install the blade in the body half. Push the resilient o-ring seal into the machined groove all the way around the blade. Insert the end of the resilient o-ring seal into the other tuck hole. Any excess o-ring seal material should be cut so that the o-ring seats securely on the bottom of the tuck hole.
11. If installing a replacement secondary seal, use the steps as listed above.
12. Close the valve by sliding the blade until it fully seats.
13. Install the Teflon corner seals to both sides of the blade where the o-ring seal enters the tuck hole.
14. Push packing pellets into the area between the resilient o-ring seal and the Teflon corner seal. An Allen wrench or other blunt ended tool will aid in this operation.
15. Gently place the back body half on the front body half, and reinstall all body screws that were previously removed.
16. Proper sealing of the resilient primary and secondary seals can be maintained during operation by further packing through the external holes on each side of the valve bodies.

Flange Bolts and Studs ASME B16.5 AND B16.47 Series A

CLASS 150		
NPS	Hex Head Flange Bolt	Flange Stud
2	5/8-11 X 1.25 Long (Qty. 4)	N/A
3	5/8-11 X 1.75 Long (Qty. 4)	N/A
4	5/8-11 X 1.75 Long (Qty. 6)	5/8-11 X 3.00 Long (Qty. 2)
5	3/4-10 X 1.75 Long (Qty. 2)	3/4-10 X 2.75 Long (Qty. 6)
6	3/4-10 X 2.00 Long (Qty. 6)	3/4-10 X 3.00 Long (Qty. 2)
8	3/4-10 X 2.25 Long (Qty. 4)	3/4-10 X 3.25 Long (Qty. 4)
10	7/8-9 X 2.25 Long (Qty. 8)	7/8-9 X 3.25 Long (Qty. 4)
12	7/8-9 X 2.25 Long (Qty. 8)	7/8-9 X 3.50 Long (Qty. 4)
14	1-8 X 2.25 Long (Qty. 8)	1-8 X 3.75 Long (Qty. 4)
16	1-8 X 2.50 Long (Qty. 10)	1-8 X 4.00 Long (Qty. 6)
18	1 1/8-8 X 2.75 Long (Qty. 10)	1 1/8-8 X 4.25 Long (Qty. 6)
20	1 1/8-8 X 3.25 Long (Qty. 12)	1 1/8-8 X 4.75 Long (Qty. 8)
22	1 1/4-8 X 3.00 Long (Qty. 12)	1 1/4-8 X 4.75 Long (Qty. 8)
24	1 1/4-8 X 3.50 Long (Qty. 12)	1 1/4-8 X 5.00 Long (Qty. 8)
26	1 1/4-8 X 4.25 Long (Qty. 14)	1 1/4-8 X 6.25 Long (Qty. 10)
28	1 1/4-8 X 4.50 Long (Qty. 18)	1 1/4-8 X 6.25 Long (Qty. 10)
30	1 1/4-8 X 4.50 Long (Qty. 18)	1 1/4-8 X 6.50 Long (Qty. 10)
32	1 1/2-8 X 4.75 Long (Qty. 16)	1 1/2-8 X 7.00 Long (Qty. 12)
36*	1 1/2-8 X 5.25 Long (Qty. 18)	1 1/2-8 X 7.25 Long (Qty. 14)
42*	1 1/2-8 X 6.25 Long (Qty. 22)	1 1/2-8 X 8.50 Long (Qty. 14)
48*	1 1/2-8 X 6.75 Long (Qty. 28)	1 1/2-8 X 8.75 Long (Qty. 16)

CLASS 300		
NPS	Hex Head Flange Bolt	Flange Stud
3	3/4-10 X 1.75 Long (Qty. 6)	3/4-10 X 3.00 Long (Qty. 2)
4	3/4-10 X 2.25 Long (Qty. 6)	3/4-10 X 3.50 Long (Qty. 2)
6	3/4-10 X 2.50 Long (Qty. 6)	3/4-10 X 3.75 Long (Qty. 6)
8	7/8-9 X 2.75 Long (Qty. 8)	7/8-9 X 4.25 Long (Qty. 4)
10	1-8 X 3.50 Long (Qty. 10)	1-8 X 4.75 Long (Qty. 6)
12	1 1/8-8 X 3.50 Long (Qty. 10)	1 1/8-8 X 5.25 Long (Qty. 6)
14	1 1/8-8 X 3.50 Long (Qty. 14)	1 1/8-8 X 5.50 Long (Qty. 6)
16	1 1/4-8 X 4.25 Long (Qty. 14)	1 1/4-8 X 5.75 Long (Qty. 6)
18	1 1/4-8 X 4.25 Long (Qty. 16)	1 1/4-8 X 6.25 Long (Qty. 8)
20	1 1/4-8 X 4.00 Long (Qty. 16)	1 1/4-8 X 6.25 Long (Qty. 8)
24	1 1/2-8 X 4.75 Long (Qty. 16)	1 1/2-8 X 7.25 Long (Qty. 8)
26	1 5/8-8 X 5.50 Long (Qty. 18)	1 5/8-8 X 8.00 Long (Qty. 10)
28	1 5/8-8 X 5.75 Long (Qty. 18)	1 5/8-8 X 8.25 Long (Qty. 10)
30	1 3/4-8 X 6.00 Long (Qty. 18)	1 3/4-8 X 8.75 Long (Qty. 10)
32	1 7/8-8 X 6.00 Long (Qty. 20)	1 7/8-8 X 9.00 Long (Qty. 8)
36*	2-8 X 7.50 Long (Qty. 22)	2-8 X 9.75 Long (Qty. 10)
42*	1 5/8-8 X 7.50 Long (Qty. 18)	1 5/8-8 X 9.75 Long (Qty. 14)
48*	1 7/8-8 X 8.25 Long (Qty. 18)	1 7/8-8 X 10.00 Long (Qty. 14)

UNIFIED COURSE THREAD SERIES (UNC)

CLASS 150		
NPS	Hex Head Flange Bolt	Flange Stud
2	5/8-11 X 1.25 Long (Qty. 4)	N/A
3	5/8-11 X 1.75 Long (Qty. 4)	N/A
4	5/8-11 X 1.75 Long (Qty. 6)	5/8-11 X 3.00 Long (Qty. 2)
5	3/4-10 X 1.75 Long (Qty. 2)	3/4-10 X 2.75 Long (Qty. 6)
6	3/4-10 X 2.00 Long (Qty. 6)	3/4-10 X 3.00 Long (Qty. 2)
8	3/4-10 X 2.25 Long (Qty. 4)	3/4-10 X 3.25 Long (Qty. 4)
10	7/8-9 X 2.25 Long (Qty. 8)	7/8-9 X 3.25 Long (Qty. 4)
12	7/8-9 X 2.25 Long (Qty. 8)	7/8-9 X 3.50 Long (Qty. 4)
14	1-8 X 2.25 Long (Qty. 8)	1-8 X 3.75 Long (Qty. 4)
16	1-8 X 2.50 Long (Qty. 10)	1-8 X 4.00 Long (Qty. 6)
18	1 1/8-7 X 2.75 Long (Qty. 10)	1 1/8-7 X 4.25 Long (Qty. 6)
20	1 1/8-7 X 3.25 Long (Qty. 12)	1 1/8-7 X 4.75 Long (Qty. 8)
22	1 1/4-7 X 3.00 Long (Qty. 12)	1 1/4-7 X 4.75 Long (Qty. 8)
24	1 1/4-7 X 3.50 Long (Qty. 12)	1 1/4-7 X 5.00 Long (Qty. 8)
26	1 1/4-7 X 4.25 Long (Qty. 14)	1 1/4-7 X 6.25 Long (Qty. 10)
28	1 1/4-7 X 4.50 Long (Qty. 18)	1 1/4-7 X 6.50 Long (Qty. 10)
30	1 1/4-7 X 4.75 Long (Qty. 18)	1 1/4-7 X 6.75 Long (Qty. 10)
32	1 1/2-6 X 4.75 Long (Qty. 16)	1 1/2-6 X 7.00 Long (Qty. 12)
36*	1 1/2-6 X 5.25 Long (Qty. 18)	1 1/2-6 X 7.25 Long (Qty. 14)
42*	1 1/2-6 X 6.25 Long (Qty. 22)	1 1/2-6 X 8.50 Long (Qty. 14)
48*	1 1/2-6 X 6.75 Long (Qty. 28)	1 1/2-6 X 8.75 Long (Qty. 16)

CLASS 300		
NPS	Hex Head Flange Bolt	Flange Stud
3	3/4-10 X 1.75 Long (Qty. 6)	3/4-10 X 3.00 Long (Qty. 2)
4	3/4-10 X 2.25 Long (Qty. 6)	3/4-10 X 3.50 Long (Qty. 2)
6	3/4-10 X 2.50 Long (Qty. 6)	3/4-10 X 3.75 Long (Qty. 6)
8	7/8-9 X 2.75 Long (Qty. 8)	7/8-9 X 4.25 Long (Qty. 4)
10	1-8 X 3.50 Long (Qty. 10)	1-8 X 4.75 Long (Qty. 6)
12	1 1/8-7 X 3.50 Long (Qty. 10)	1 1/8-7 X 5.25 Long (Qty. 6)
14	1 1/8-7 X 3.50 Long (Qty. 14)	1 1/8-7 X 5.50 Long (Qty. 6)
16	1 1/4-7 X 4.25 Long (Qty. 14)	1 1/4-7 X 5.75 Long (Qty. 6)
18	1 1/4-7 X 4.25 Long (Qty. 16)	1 1/4-7 X 6.25 Long (Qty. 8)
20	1 1/4-7 X 4.00 Long (Qty. 16)	1 1/4-7 X 6.25 Long (Qty. 8)
24	1 1/2-6 X 4.75 Long (Qty. 16)	1 1/2-6 X 7.25 Long (Qty. 8)
26	1 5/8-6 X 5.50 Long (Qty. 18)	1 5/8-6 X 8.00 Long (Qty. 10)
28	1 5/8-6 X 5.75 Long (Qty. 18)	1 5/8-6 X 8.25 Long (Qty. 10)
30	1 3/4-5 X 6.00 Long (Qty. 18)	1 3/4-5 X 8.75 Long (Qty. 10)
32	1 7/8-8 X 6.00 Long (Qty. 20)	1 7/8-8 X 9.00 Long (Qty. 8)
36*	2-4 1/2 X 7.50 Long (Qty. 22)	2-4 1/2 X 9.75 Long (Qty. 10)
42*	1 5/8-6 X 7.50 Long (Qty. 18)	1 5/8-6 X 9.75 Long (Qty. 14)
48*	1 7/8-8 X 8.25 Long (Qty. 18)	1 7/8-8 X 10.00 Long (Qty. 14)

Hex screws and studs sized according to the use of the following hardware:

- Nuts per ASME B18.2.2 dimensions.
- Gasket thickness of .06 of an inch.
- Washers per ASTM F436 dimensions.
- Flange fitting per ASME B16.5 and B16.47 series A.

End user to assure that any deviation from these components is accounted for when selecting screw and bolt length.

*Estimate—Subject to Change

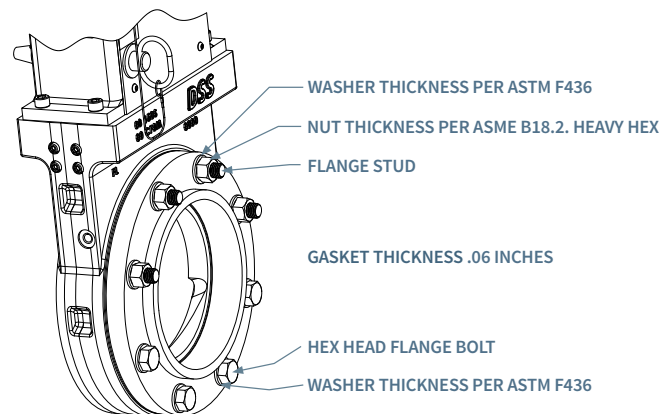

Design Specs, Material List and Torque Values

DESIGN SPECIFICATIONS

All DSS Valves meet the following design and build specifications:

API 598

ASME 16.34

ASME 16.47

ASME 16.5

MSS SP-25

MSS SP-55

MSS SP-81

MSS SP-135

MSS SP-151

MSS SP-152

Torque =

$(\text{Nut Factor}) * (\text{Clamp Load}) * (\text{Thread Major Diameter})$

Gasket Load =

$(\text{Number of Bolts}) * (\text{Clamp Load})$

Gasket Stress =

$(\text{Gasket Load}) / (\text{Gasket Area})$

MATERIALS					
Code	Cast		Wrought		Common Name
	Standard/Grade	UNS	Standard/Grade	UNS	
17	A747 CB7Cu-1	J92180	A693	S17400	17-4 PH
22	A995 Gr. 4A CD3MN	J92205	A240	S31803	Duplex 2205
25	A995 Gr. 5A CE3MN	J93404	A240	S32750	Super Duplex 2507
31	-	-	B625	N08031	Alloy 31/Nicrofer 3127 hMo
37	A351 CG8M	J93000	A240	S31700	317 SS
94	-	-	B625	N08904	904L
6X	A351 CN3MN	J94651	A240/B688	N08367	AL6XN
A2	A351 CN7M	N08007	B463	N08020	Alloy 20
CS	A216 WCB	J13345	A516 Gr. 70	-	Carbon Steel
DI	A536 65-45-12	F33100	-	-	Ductile Iron
DN	A439 D2	F43000	-	-	Ni-Resist D2
HC	A494 CW12MW	N30002	B575	N10276	Hastelloy C-276
NI	A436 Gr. 1	F41000	-	-	Ni-Resist 1
SS	A351 CF8M	J92900	A240	S31600	316 SS
T2	B367 Gr. C-2	R50400	B265 Gr. 2	-	Titanium Gr.2
T5	B367 Gr. C-5	R56400	B265 Gr. 5	-	Titanium Gr.5
T8	B367 Gr. C-8	R54810	B265 Gr. 8	-	Titanium Gr.8
TT	B367 Gr. C-12	R53400	B265 Gr. 12	-	Titanium Gr.12
XX	-	-	-	-	Other

TORQUE VALUES TO INDUCE BOLT STRESS

Thread Major [in]	Threads/Inch	Tensile Stress Area [in ²]	Nut Factor [K]	30,000 psi		45,000 psi		60,000 psi	
				Torque [ft-lbf]	Clamp Load [lbf]	Torque [ft-lbf]	Clamp Load [lbf]	Torque [ft-lbf]	Clamp Load [lbf]
0.625	11	0.226	0.19	67	6780	101	10170	134	13560
0.75	10	0.3345	0.177	111	10034	166	15051	222	20068
0.875	9	0.4617	0.175	177	13852	265	20778	354	27704
1	8	0.6057	0.178	270	18172	404	27259	539	36345
1.125	8	0.7905	0.173	385	23714	577	35571	769	47427
1.25	8	0.9997	0.172	537	29991	806	44987	1075	59983
1.375	8	1.2335	0.171	725	37005	1088	55508	1450	74010
1.5	8	1.4918	0.152	850	44755	1276	67133	1701	89511

Troubleshooting

PROBLEM	POSSIBLE CAUSE	RECOMMENDATIONS
Leaking through yoke end	Primary or secondary seals are damaged	Follow primary and secondary seals replacement guide in IOM.
	Insufficient packing pressure on primary and secondary seals	Follow repacking instruction in IOM.
Leaking past gate	Improper limit switch adjustment	Consult factory for adjustment procedure.
	Improper seating in closed position	Ensure that gate is fully compressing resilient seals upon closure. Consult factory for assistance.
	Compromised primary gate seal	Inspect visible seal in valve bore for damaged or dislodged resilient seal. Consult factory for repair options.
	Insufficient packing pressure on primary and secondary seals	Follow repacking instruction in IOM.
Leaking between body halves	Compromised secondary seal	Consult factory for repair options.
	Body screws improperly torqued	Consult factory for repair options.
	Improper spacing between mating pipe flanges	Check spacing between flanges and ensure that it is the same as valve face to face.
Valve will not open or close	Lockout-tagout pin left in	Remove the lockout-tagout pin; See instructions in IOM.
	Cylinder issues	Check the cylinder for supply pressure issues. Refer to troubleshooting guide supplied by cylinder manufacturer.
		Inspect all pressure connections, tubes, and hoses for leaks. Repair and or replace all damaged or malfunctioning hardware.
	Flange screws which are too long may cause gate to seize when torqued properly	Loosen screws and replace with screws of the correct length. Alternatively, use studs with nuts.
	Overpacked primary and secondary seals	Remove packing screws and attempt to actuate valve. If over packed valve should begin to actuate. Repack valve according to IOM instructions.
	Damaged power screw	Inspect power screw for damage. Consult factory for repair or replacement.
	Dirty power screw	Inspect power screw for dirt which could cause excessive actuation or seizing. Clean power screw. Do not lubricate screw for any reason.
	Damaged clevis/pin or screw nut drive hub	Inspect clevis pin/drive hub for damage and replace if needed.
Damaged gate	Check to insure that gate is not damaged.	
Actuator not stroking	Lockout-tagout pin left in	Remove the lockout-tagout pin; See instructions in IOM.
	Limit switch malfunction	Replace, repair or adjust limit switches.
	Electric actuator malfunction	Check limit switches, power source; refer to actuator manual.
	Pneumatic actuator malfunction	Check power source and supply; Check solenoid valve and replace/repair if damaged; Refer to actuator manual.
	Spring return	Ensure that power source can supply enough pressure to overcome cylinder spring force.
	Damaged gate	Check to insure that gate is not damaged.
Open lockout-tagout pin will not engage	Improper limit switch adjustment	Consult factory for adjustment procedure.

Ordering Information

TYPE	SERIES	FLANGE	SIZE

BODY

GATE

TYPE	P/N
Severe Service Knife Gate Valve	SV
Double Block and Bleed Valve	DB
Transmitter Isolation Valve	TI
Round to Square Knife Gate Valve	RS
Soft Start Paste Valve	PV
Control Valve	CV
Through Gate Valve	TG

SERIES	P/N
Class 150	1
Class 300	3
Class 600	6
Class 900	9

FLANGE	P/N
SP 135 Short, ASME B16.5 [2" to 24"]	S
SP 135 LONG, ASME B16.5 [2" to 24"]	L
SP 135 Short, ASME B16.47 [26" to 60"] Series A	S
SP 135 Long, ASME B16.47 [26" to 60"] Series A	L
ASME B16.47 [26" to 60"] Series B	J
AS 2129 - Table D	D
AS 2129 - Table E	E
DIN 2501 - PN10	T
DIN 2501 - PN16	P
DIN 2501 - PN25	W
DIN 2501 - PN40	F

Please note: Maximum pressure rating of valve will not exceed the ratings for the flange standard selected. Consult factory for other flange options.

SIZE	P/N
1 inch	01
1.5 inch	1H
2 inch	02
2.5 inch	2H
3 inch	03
4 inch	04
5 inch	05
6 inch	06
7 inch	07
8 inch	08
10 inch	10
12 inch	12
14 inch	14
16 inch	16
18 inch	18
20 inch	20
22 inch	22
24 inch	24
26 inch	26
28 inch	28
30 inch	30
32 inch	32
36 inch	36
40 inch	40
42 inch	42
48 inch	48
60 inch	60
Other (specify)	XX

BODY MATERIAL	P/N
17.4 PH [A747 CB7Cu-1]	17
316 SS [A351 CF8M]	SS
317 SS [A351 CG8M]	7S
AL6XN [A351 CN3MN]	6X
Alloy 20 [A351 CN7M]	A2
Carbon Steel [A216 WCB]	CS
Cast Iron [A536 65-45-12]	CI
Duplex 2205 [A995 Gr. 4A CD3MN]	22
Hastelloy C-276 [A494 CW12MW]	HC
Ni-Resist 1 [A436 Gr. 1]	NI
Ductile Ni-Resist D2 [A439 D2]	DN
Super Duplex 2507 [A995 Gr. 5A CE3MN]	25
Titanium Grade 2 [B367 Gr. C-2]	T2
Titanium Grade 5 [B367 Gr. C-5]	T5
Titanium Grade 7 [B367 Gr. C-7]	T7
Titanium Grade 8 [B367 Gr. C-8]	T8
Titanium Grade 12 [B367 Gr. C-12]	TT
Aluminum	AL
Other (specify)	XX

GATE MATERIAL	P/N
17.4 PH [A693]	17
316 SS [A240]	SS
AL6XN [A240/B688]	6X
Carbon Steel [A516 Gr. 70]	CS
D55 Tool Steel	D5
Duplex 2205 [A240]	22
Hastelloy C-276 [B575]	HC
Super Duplex 2507 [A240]	25
Titanium Grade 2 [B265 Gr. 2]	T2
Titanium Grade 5 [B265 Gr. 5]	T5
Titanium Grade 7 [B367 Gr. C-7]	T7
Titanium Grade 8 [B265 Gr. 8]	T8
Titanium Grade 12 [B265 Gr. 12]	TT
Aluminum	AL
Other (specify)	XX

VALVE SEALS	-	SCRAPERS	-	ACTUATION	CYLINDER SIZE	ACT. SEALS	-	OPTION	-	OPTION	-	OPTION
--------------------	---	-----------------	---	------------------	----------------------	-------------------	---	---------------	---	---------------	---	---------------

SEALS	P/N
Aflas [25 to 450°F] [-4 to 230°C]	AF
Buna N [-30 to 250°F] [-34 to 121°C]	BN
Chemraz [-20 to 600°F] [-28 to 315°C]	CH
EPDM [-65 to 265°F] [-54 to 129°C]	EP
GFLT Viton [-29 to 437°F] [-34 to 225°C]	GF
Graphite [Temperature limited by valve body materials]	GR
Polyurethane [-30 to 180°F] [-34 to 82°C]	PL
Teflon [-328 to 500°F] [-200 to 260°C]	TF
Viton [-15 to 437°F] [-26 to 225°C]	VI
Special (specify)	XX

SCRAPERS	P/N
Phenolic	1
Stainless	2
Brass	3
Special (Specify)	0

ACTUATION	P/N
Bare Yoke	BY
Bevel Gear	BG
Chainwheel	CW
Electric Actuator	EA
Gate & Body Only	GB
Gear Operator	GO
Handwheel	HW
Hydraulic Cylinder	HC
Low Profile	LP
Oversize Handwheel	OH
Pneumatic Cylinder	PC
Ratchet Handle	RH
Spring Extend [Fail Close]	SC
Spring Return [Fail Open]	SO

ACTUATION SEALS	P/N
Standard [-30°F to 250°F] [-34 to 121°C]	S
Low Temp [-70°F to 200°F] [-57°C to 93°C]	L
High Temp [-20°F to 250°F] [-29°C to 121°C]	H

BUILD OPTIONS	
Wear Ring (Inlet & Outlet)	S1
Wear Ring (Inlet)	S2
Bore Reducer (Inlet & Outlet)	S3
Bore Reducer (Inlet)	S4
V-Port	S5
Drilled Through Flange Holes	S6
Chest Relief	S7
Gate Guide Modification	S8
Purge Ports (Chest)	S9
Purge Ports (Nose)	S10
Stainless Steel Top Structure (304)	S11
Stainless Steel Top Structure (316)	S12
Stainless Steel Bolts (316)	S13

BUILD OPTIONS CONTINUED	
Stainless Steel Bolts (304)	S14
Stellite Tipped Gate	S15
Hardchrome Gate	S16
Hardfaced Port	S17
Raised Face Flange	S18
Xylan Bodies & Gate	S19
Xylan Gate	S20
Special Paint TopWorks	S21
Special Paint Actuator	S22
Limit Switches	S23
Proximity Switches [HAWKEYE]	S24
Positioner	S25
Position Indicator	S26
Control Solenoid	S27
Chrome Carbide Gate Nose	S28
UNC Flange Threads	S29
Lifting Lugs	S30
Extended Flushout Ports	S31
Prox/Limit Switch Prep only	S32
Reed Switch Cylinder Prep	S33
Metal Bonnet Covers (304SS)	S34
Manual Override [Cylinder]	S35
Internal Transducer [Baluff]	S36
Internal Transducer [ROTA]	S37
Rod boot [Cylinder]	S38
Low Profile [Cylinder]	S39
Body Material Compatible Drain Plugs [DBB Valves]	S40
Xylan Coated Bolts	S41
Clear Xylan Bodies & Gate	S42
Clear Xylan Gate	S43
SevereGuard Bodies & Gate	S44
White Xylan Bodies & Gate	S45
White Xylan Gate	S46
Expanded Metal Bonnet Covers (304SS)	S47
SevereGuard Gate	S48
Corrosive/Marine Coating [Cylinder]	S49
Ultra Corrosive Construction [Cylinder]	S50
High Temp Construction [Cylinder]	S51
High Vibration Construction [Cylinder]	S52
Prox/Limit Switch Prep Only 316SS	S53
Positive Lock Out	S54
Other (Specify)	S99





ISO 9001:2015 Certified



Contact Us

DSS Valves
1800 Mayflower Road
Niles, MI 49120
USA

TEL: 269-409-6080
FAX: 269-409-6099
info@dssvalves.com
DSSVALVES.COM